

ISBN 978-0-626-27962-2

SANS 10087-7:2013

Edition 4

SOUTH AFRICAN NATIONAL STANDARD

The handling, storage, distribution and maintenance of liquefied petroleum gas in domestic, commercial, and industrial installations

Part 7: Storage and filling premises for refillable liquefied petroleum gas (LPG) containers of gas capacity not exceeding 19 kg and the storage of individual gas containers not exceeding 48 kg

WARNING

This standard references other documents normatively.

Published by SABS Standards Division
1 Dr Lategan Road Groenkloof ☒ Private Bag X191 Pretoria 0001
Tel: +27 12 428 7911 Fax: +27 12 344 1568

www.sabs.co.za

© SABS

SABS

SANS 10087-7:2013

Edition 4

Table of changes

Change No.	Date	Scope

Foreword

This South African standard was approved by National Committee SABS/TC 1019, *Gas supply, handling and control (fuel, industrial and medical gases)*, in accordance with procedures of the SABS Standards Division, in compliance with annex 3 of the WTO/TBT agreement.

This document was published in January 2014.

This document supersedes SANS 10087-7:2011 (edition 3.1).

This document is referenced in the Occupational Health and Safety Act, 1993 (Act No. 85 of 1993), and the National Building Regulations and Building Standards Act, 1977 (Act No. 103 of 1977).

This document was written in order to support a specific South African Regulation and, of necessity, includes references to South African legislation. It therefore might not be suitable for direct application in other jurisdictions where conflicting legislation exists.

SANS 10087 consists of the following parts, under the general title, *The handling, storage, distribution and maintenance of liquefied petroleum gas in domestic, commercial, and industrial installations*:

Part 1: Liquefied petroleum gas installations involving gas storage containers of individual water capacity not exceeding 500 L and a combined water capacity not exceeding 3 000 L per installation.

Part 2: Installations of LPG systems in mobile units, including but not limited to caravans, motor homes, park homes and mobile kitchens.

Part 3: Liquefied petroleum gas installations involving storage vessels of individual water capacity exceeding 500 L.

Part 4: The transportation of LP gas including the design, construction, inspection, fittings, filling, maintenance and repair of LP gas bulk vehicles and rail tank cars.

Part 6: The application of liquefied petroleum and compressed natural gases as engine fuels for internal combustion engines.

Part 7: Storage and filling premises for refillable liquefied petroleum gas (LPG) containers of gas capacity not exceeding 9 kg and the storage of individual gas containers not exceeding 48 kg.

Part 8: Filling containers for LP gas operated fork lift vehicles in-situ.

Part 10: Mobile filling stations for refillable liquefied petroleum gas (LPG) containers of capacity not exceeding 9 kg.

SANS 10087-7:2013

Edition 4

Introduction

In compiling this document, the possible dangers arising as a result of the specific properties of LPG were taken into consideration together with the dangers resulting from the physical operation of filling the containers. Other dangers associated with aspects of filling include incorrect siting of filling facilities, employing untrained personnel and a lack of proper supervision.

Compliance with this document does not, however, confer immunity from relevant legal requirements and the jurisdictional authority of the local fire authority. Where mandatory requirements are applicable, the local fire authority should be approached to ensure compliance.

When small, non-refillable gas cartridges (for lamps, stoves, etc.) are stocked for resale, it is recommended that the quantities involved and the position of storage be in accordance with local by-laws and the appropriate fire department requirements. See also SANS 10263-0.

This document should be interpreted in light of the merits and demerits of each situation, and deviations from the requirements of this document should only be proposed after consultation with and acceptance by the appropriate authority or the local fire department.

SANS 10087-7:2013

Edition 4

Contents

	Page
Foreword	
Introduction	1
1 Scope	3
2 Normative references	3
3 Definitions	4
4 Properties of LPG and precautions to be observed	6
5 Location, design and control of filling premises with or without a storage area	7
6 Filling equipment	10
7 Containers	11
8 Operators	11
9 Inspection procedure	12
10 Filling procedure	14
11 Handling and storage of LPG containers	15
12 Prevention and control of fires involving LPG	19
Figures 1-11	21-30
Bibliography	31

The handling, storage, distribution and maintenance of liquefied petroleum gas in domestic, commercial, and industrial installations

Part 7:

Storage and filling premises for refillable liquefied petroleum gas (LPG) containers of gas capacity not exceeding 19 kg and the storage of individual gas containers not exceeding 48 kg

1 Scope

1.1 This part of SANS 10087 specifies:

- a) the minimum requirements for the location and installation of gas supply systems at premises for the filling of liquefied petroleum gas (LPG) containers of gas capacity not exceeding 19 kg; and
- b) the requirements for the storage of individual gas containers not exceeding 48 kg.

1.2 This part of SANS 10087 also identifies safe methods for the filling and storage of refillable containers and makes recommendations on safe working procedures that cover all aspects of the storage of containers.

1.3 This part of SANS 10087 also covers the storage of non-refillable containers.

2 Normative references

The following referenced documents are indispensable for the application of this document. For dated references, only the edition cited applies. For undated references, the latest edition of the referenced document (including any amendments) applies. Information on currently valid national and international standards can be obtained from the SABS Standards Division.

SANS 543, *Fire hose reels (with semi-rigid) hose.*

SANS 1128-1; *Firefighting equipment – Part 1: Components of underground and above-ground hydrant systems.*

SANS 1186-1, *Symbolic safety signs – Part 1: Standard signs and general requirements.*

SANS 1475-1, *The production of reconditioned fire-fighting equipment – Part 1: Portable and wheeled (mobile) rechargeable fire extinguishers.*

SANS 10087-7:2013

Edition 4

SANS 1475-2, *The production of reconditioned fire-fighting equipment – Part 2: Fire hose reels and above-ground hydrants.*

SANS 1825, *Gas cylinder test stations – General requirements for periodic inspection and testing of transportable refillable gas pressure receptacles.*

SANS 1910, *Portable refillable fire extinguishers.*

SANS 10019, *Transportable pressure receptacles for compressed, dissolved and liquefied gases – Basic design, manufacture, use and maintenance.*

SANS 10086-1, *The installation, inspection and maintenance of equipment used in explosive atmospheres – Part 1: Installations including surface installations on mines.*

SANS 10087-1, *The handling, storage, distribution and maintenance of liquefied petroleum gas in domestic, commercial, and industrial installations – Part 1: Liquefied petroleum gas installations involving gas storage containers of individual water capacity not exceeding 500 L and a combined water capacity not exceeding 3 000 L per installation.*

SANS 10087-3, *The handling, storage, distribution and maintenance of liquefied petroleum gas in domestic, commercial and industrial installations – Part 3: Liquefied petroleum gas installations involving storage vessels of individual water capacity exceeding 500 L.*

SANS 10105-1, *The use and control of fire-fighting equipment – Part 1: Portable and wheeled (mobile) fire extinguishers.*

SANS 10105-2, *The use and control of fire-fighting equipment – Part 2: Fire hose reels and above-ground hydrants.*

SANS 10108, *The classification of hazardous locations and the selection of apparatus for use in such locations.*

SANS 10400 (SABS 0400), *The application of the National Building Regulations.*

3 Definitions

For the purposes of this document, the following definitions apply.

3.1

acceptable

acceptable to the authority administering this part of SANS 10087, or to the parties concluding the purchase contract, as relevant

3.2

approved

approved by the approving authority

3.3

approving authority

appropriate of the following:

- a) within the scope of the Occupational Health and Safety Act, 1993 (Act No. 85 of 1993): the Chief Inspector;
- b) within the scope of the Mine Health and Safety Act, 1996 (Act No. 29 of 1996): the Chief Inspector; and
- c) within the scope of SANS 10400: the local authority concerned

4

3.4

boundary wall

wall built on the perimeter of a property and so placed that it forms a built-up barrier between that property and any adjoining property or street front

3.5

competent person

any person that has the knowledge, training and experience specific to the work or task being performed

3.6

container

vessel approved for the storage and conveyance of liquefied petroleum gas and of capacity not exceeding 48 kg

3.7

diversion wall

a solid non-combustible wall erected with the specific purpose of ensuring and maintaining the appropriate safety distances between the point of gas release and any drains, doors and windows in buildings, and possible sources of ignition, for example electrical apparatus, etc.

NOTE: A solid wall may only be built as specified in SANS 10400-K

3.8

filling area

area that comprises the following equipment:

- a) filling pump,
- b) manifolded containers,
- c) filling point, and
- d) filling scale

3.9

filling enclosure

enclosure that includes a filling area (which may include a storage area) that is expressly equipped and used for refilling or storage (or both) of gas containers

3.10

filling equipment

all the equipment required for refilling containers that are either empty or partially empty

3.11

filling point

point on the filling equipment to which the empty or partially empty container is connected for the purpose of refilling

3.12

firewall

solid non-combustible wall with a fire rating of 240 min and height of at least 1,8 m, constructed and placed with the specific purpose of preventing the spread of fire as a result of the radiation of heat or direct flame impingement,

NOTE 1 According to SANS 10400, a firewall is a double brick wall of a minimum width of 190 mm or reinforced concrete wall of a width of 150 mm or other barrier with a fire rating of at least 240 minutes.

NOTE 2 A solid wall may only be built as specified in SANS 10400-K

SANS 10087-7:2013

Edition 4

3.13

liquefied petroleum gas

LPG

commercial butane, commercial propane, or a mixture of light hydrocarbons (predominantly propane, propene, butane and butene) that is gaseous under conditions of ambient temperatures and pressure, and that is liquefied by an increase of pressure or a lowering of temperature

3.14

purpose-designed vehicle

vehicle that is purposely designed and constructed to be used in hazardous locations.

3.15

qualified operator

person who has received training, documented by the employer, in the filling of LPG containers (see SANS 10019)

3.16

shipping container

ventilated steel enclosure used for the purpose of secure storage or filling of gas containers (or both)

3.17

source of ignition

spark, flame or hot object produced by any means and capable of igniting LPG-air mixtures

3.18

suitable

capable of fulfilling or having fulfilled the intended function, or fit for its intended purpose

3.19

supply container

container of liquid withdrawal type fitted with eductor tube that complies with SANS 10019, that is approved for the storage and conveyance of liquefied petroleum gas of individual water capacity not exceeding 500 L

4 Properties of LPG and precautions to be observed

The location and installation of, and operations at, premises where containers are filled with LPG, particularly those on the premises of retail outlets, shall be planned and put into effect with full regard for the properties of the gas. All persons concerned with the storage, handling and use of LPG shall be qualified in these respects and shall be familiar with the following characteristics of the gas and the precautions to be observed:

- a) The gas is stored as liquid under pressure.
- b) Leakage, especially of liquid, will release large volumes of highly flammable gas.
- c) LPG vapours become flammable when mixed with air. Gas-air mixtures that contain approximately 1,5 % to 10 % of LPG are flammable. If a large enough volume of gas is so dispersed in the atmosphere as to reach flammable proportions throughout, ignition of the mixture will result in a rate of combustion of near-explosive intensity, and an explosion will occur when such gas-air mixtures are ignited while contained in a confined space.

SANS 10087-7:2013

Edition 4

- d) LPG is heavier than air and will flow along the ground or through drains. It can be ignited at a considerable distance from the source of leakage, therefore low-level ventilation shall be provided.
- e) LPG is non-toxic, but since it can induce headaches and dizziness when inhaled, inhalation of LPG should be avoided whenever possible.
- f) LPG, by its rapid vaporization and consequent lowering of the temperature, can cause severe cold burns when it comes into contact with the skin. Appropriate protective clothing, such as gloves, goggles, aprons and boots etc., shall be worn when there is any possibility of contact with the skin.
- g) A container that has held LPG and has been "emptied" is still considered dangerous. In this state, the internal pressure is approximately atmospheric and, if the valve leaks or is left open, air can diffuse into the container and form a flammable or explosive mixture. Furthermore, even an "empty" container that does not yield gas when the valve is opened, might in fact not be quite empty. In cold weather, the heavier fractions of the liquid might not vaporize and will therefore remain in the container. Therefore a container that is empty or appears to be empty shall be handled with the same care as a full container.
- h) Valves shall be kept closed at all times when containers are not in use.

5 Location, design and control of filling premises with or without a storage area

5.1 Approval for the establishment and operation of filling premises that fall within the scope of this part of SANS 10087 shall be obtained from the approving authority. Guidance on the type, installation and operation of filling equipment shall be obtained from the company that supplies the filling equipment or gas (or both).

5.2 The filling area shall not be inside any building (unless purposely designed for filling of containers, for example a shipping container (see figure 1)) or near any combustible materials and any possible source of ignition. The storage of gas shall be limited to 500 kg.

NOTE In the context of this part of SANS 10087, a shipping container is not deemed to be a building as defined in the National Building Regulations.

No window shall be within 1 m horizontally, and 3 m vertically of the filling point and manifold. Windows within 3 m of the boundary of the filling area shall be of the non-opening type and shall be glazed with wired glass. The sill height shall be at least 1,2 m above ground level.

5.3 The total mass of the gas in the filling area shall be limited to 500 kg. Where the gas supply source is greater than 500 kg, the manifold system shall be outside the boundary of the filling area. It shall be positioned:

- a) behind a firewall; or
- b) 3 m from the boundary of the filling area.

5.4 The boundary of the filling area shall be at least 3 m away from

- a) the boundary of the premises where it is located, except that when a firewall is provided, the boundary of the filling area may be against the firewall, and the safety distance (see 11.2.5) is measured horizontally around the firewall,
- b) any vehicle roadway or parking area (including customer collection points),

SANS 10087-7:2013

Edition 4

- c) any drain or depression that could convey and release LPG beyond the boundary of the premises, and
- d) any pit, any opening to a basement or to underground equipment and any door that can be opened.

5.5 Ventilation apertures in a shipping container shall be fitted with rodent-proof grids, and shall have a combined minimum area of 10 % of the floor area. These ventilation slots shall be permanently open.

NOTE 1 As few filled containers as possible should be displayed in a retail shop and dummies should be used for containers with an LPG capacity greater than 0,45 kg.

NOTE 2 These safety distances are based on the assumption that the filling equipment and the filling procedure comply with the requirements of this part of SANS 10087. The jurisdicative authority should be consulted in case of doubt.

5.6 The filling area shall be so located and protected that the filling equipment is protected against damage that could be caused by persons or vehicles.

5.7 Unauthorized persons shall not be allowed to enter the filling area. Where unauthorized persons (public or tenants) cannot be prevented from entering the section of premises where the filling area is situated, the filling area shall be enclosed by a fence (of wire mesh or other approved material) of height at least 1,8 m that has an outward-opening gate that shall be kept locked when not in use and that has an alternative means of escape, for emergencies, that can be unlatched from the inside.

5.8 The filling area may have a roof to provide weather protection and to protect the filling equipment from direct sunlight, provided that the roof is made of non-combustible material. The roof, when fitted, shall be at least 2,4 m above floor level and so designed as to allow free movement of air past the filling equipment and the qualified operator.

5.9 Boundary walls shall comply with the relevant requirements of SANS 10400 and shall be of height at least 1,8 m. Should the boundary wall be required to be a firewall, it shall be at least 230 mm thick with no openings.

5.10 Diversion walls shall have a height sufficient to effectively divert any gas discharge to ensure that, when measured around and over the wall, the required safety distances are complied with. Where a firewall is required, it shall be of height 1,8 m and 230 mm thick. A maximum of two firewalls joined perpendicularly, at an angle that is not less than 90°, shall be allowed.

5.11 Where climatic conditions necessitate the provision of side sheeting or walling (excluding firewalls and boundary walls), it shall be of a non-combustible material and ventilation shall be provided at ground and eaves level to prevent the accumulation of gas.

Where side sheeting is used, it shall terminate at least 150 mm below the eaves and 150 mm above ground level. Where solid walls other than firewalls or screening walls are used, either the above spacing shall apply or airbricks (without vermin-proof gauze) spaced not more than 250 mm apart shall be provided in all the walls at ground and eaves level.

5.12 The filling area shall be at ground level or comprise a raised platform made of non-combustible material. The floor shall be level, flat and firm, of a non-combustible material, and shall not contain pits or underfloor openings.

5.13 Fixed electrical equipment and wiring installed within the filling area shall be selected in accordance with the requirements of SANS 10086-1 and SANS 10108, appropriate to the following:

SANS 10087-7:2013

Edition 4

- a) installation within 2 m of the filling point in all directions: equipment suitable for zone 1 hazardous locations, and
- b) installation beyond 2 m but within 5 m of the filling point in all directions: equipment suitable for zone 2 hazardous locations.

NOTE The requirements given in (a) and (b) are not applicable beyond an unpierced wall, a roof or a solid vapour-tight partition.

The most common sources of ignition are naked lights, fires, exposed incandescent material, electric welding arcs, gas welding and cutting flames, unprotected motors, fuses, plugs or switches, and lamps of an unapproved pattern. Reference shall be made to the Electrical Machinery in Hazardous Locations, Regulation 8 of the Occupational Health and Safety Act, 1993 (Act No. 85 of 1993) in connection with the installation of electrical equipment in hazardous areas.

5.14 At least two sets of symbolic safety signs, that comply with the requirements of SANS 1186-1 for

- a) PV 1 signs (smoking prohibited),
- b) PV 2 signs (fire or lights (or both) prohibited),
- c) PV 3 signs (thoroughfare for pedestrians prohibited), and
- d) PV 27 signs (cellular phones prohibited)

shall be placed at the boundary of the filling enclosure. One set of symbolic safety signs shall be placed in the case of storage facilities for less than 250 kg. The position and method of placement shall be in accordance with approved practice. Each sign shall be of dimensions at least 190 mm × 190 mm.

5.15 A filling enclosure shall be equipped with at least one approved fire extinguisher of the dry-chemical type and of capacity at least 9 kg, provided that the total capacity of the filling container(s) does not exceed 50 kg of LPG. An additional fire extinguisher shall be provided in cases where the capacity of the filling container exceeds 50 kg. All fire extinguishers shall be installed on the premises and outside the boundary of the filling enclosure, but close to the point of entry to the filling enclosure.

Dry-chemical powder type fire extinguishers shall comply with the requirements of SANS 1910. Their classification, use and maintenance shall be in accordance with SANS 1475-1 and SANS 10105-1.

A water supply incorporating a fire hose reel and a spray-type nozzle that comply with SANS 543 shall also be available on the premises, but shall be located outside the filling enclosure. Where the water supply is restricted, the local authority shall be consulted. Their use and maintenance shall be in accordance with SANS 1475-2 and SANS 10105-2. Where Fire Hydrants are required it shall comply with SANS 1128-1 and the use and maintenance shall comply with SANS 1475-2 and SANS 10105-2

5.16 The total capacity of gas containers (including the filling containers) within the filling area shall not exceed 1 500 kg. Any excess containers shall be removed to a storage area (see 11.2). The filling area shall not be less than 15 m².

SANS 10087-7:2013

Edition 4

5.17 During filling operations, vehicles other than purpose-designed vehicles shall not be operated within 5 m of the filling point.

5.18 The carrying of matches, lighters and other sources of ignition within the filling enclosure shall be prohibited.

6 Filling equipment

6.1 General

The filling equipment shall be securely mounted on a permanent support constructed of non-combustible material.

6.1.1 The siting of filling containers shall be inside the filling area.

6.1.2 In the case of individual bulk filling containers (i.e. containers the capacity of which exceeds 500 L), all the applicable requirements of SANS 10087-3 shall apply.

6.2 Gas supply for the filling system

6.2.1 All supply containers shall be of the liquid withdrawal type and shall be equipped with an eductor tube.

6.2.2 Containers shall not be filled by means of inverting vapour withdrawal containers.

6.2.3 Filling supply may be from any one of the following:

- a) a single container of a maximum water capacity of 500 L; or
- b) a bank of manifolded containers.

6.2.4 When 48 kg containers are manifolded, they shall not exceed 10 containers per manifold branch.

6.2.5 The maximum mass of the manifold system shall be 1000 kg.

6.2.6 When a manifold is used it shall be of the liquid withdrawal type and shall be designed and maintained in accordance with the requirements of SANS 10087-1.

6.2.7 A bank of manifolded dumpy containers shall not consist of more than 6 containers in total.

6.2.8 When a manifold is used it shall comply with the requirements for piping (see SANS 10087-1).

NOTE This part of SANS 10087-7 does not cover the supply of gas from bulk containers of individual capacity exceeding 500 L.

6.3 Filling system

6.3.1 Containers shall be filled by mass measurement only (in other words, pressure filling by means of a suitable pump). The various methods of filling by volume measurement, which inevitably entail the venting of large volumes of gas into the atmosphere (both during filling and during verification that a container has not been filled beyond its permissible filling ratio), shall not be permitted.

SANS 10087-7:2013

Edition 4

6.3.2 Containers shall be filled in accordance with mass measurements. The resolution of mass measuring equipment shall meet the filling tolerances in 10.1.

6.3.3 The filling system shall consist of a pump (either manually or power operated) in conjunction with the necessary auxiliary equipment. Any permanent pipe systems shall be installed and approved by a registered installer in accordance with SANS 10087-1. A typical filling system is shown in figure 2 and typical filling areas, equipment and enclosures are shown in figures 3 to 7.

6.3.4 The connection between the filling equipment and the container to be filled shall be so designed that, on release, not more than 10 mL of liquid is released.

6.3.5 When multiple filling points are found in a filling area and they are not placed back to back, a minimum separation of 1 m shall be maintained between individual filling points. The electrical zoning requirements as in 5.13 shall be calculated based on the location of each filling point.

7 Containers

7.1 Approved containers

A container shall not be filled unless it has been inspected by the filler or a competent person and it has been found to comply with SANS 10019.

7.2 Defective containers

Containers that appear to be defective in any respect (see 9.1.2) or have valves that do not function correctly, shall not be refilled. The filler shall advise the customer of all the dangers posed by a defective container, and shall obtain the container for the purpose of safe disposal.

8 Operators

8.1 Qualifications, training and experience of operators

The person who inspects, fills and handles the containers in terms of this part of SANS 10087, shall have the appropriate technical and practical training for the type of work undertaken, the proof of which both employer and employee shall document (see 8.2) and which shall cover the following applicable topics:

- a) the properties of LPG;
- b) container inspection;
- c) container filling procedures;
- d) container storage and transportation;
- e) emergency action plan; and
- f) knowledge of the relevant standards and legal requirements.

8.2 Record of operator training

A record shall be kept on the premises of the training undergone by an employee in terms of 8.1. This record shall contain the training course syllabus, the name of the trainer and the name of the trainee.

8.3 Authority of qualified operators

No one shall inspect, fill or handle a container unless

- a) he has been duly trained (see 8.1),

SANS 10087-7:2013

Edition 4

- b) his training has been recorded (see 8.2),
- c) he has been found competent to fill containers in accordance with this part of SANS 10087, and
- d) written permission to fill the container has been granted by the owner of the container. This condition does not apply in instances where the container is owned by the end user.

NOTE The requirement in 8.3 (d) is for safety reasons, since the past usage details of the container is essential for correct filling. It is illegal to fill in the container without the written permission of the owner.

9 Inspection procedure

9.1 Inspection before filling with LPG

9.1.1 Container markings

Before any container is filled, inspect it to ensure that the following markings are clearly visible and legible:

- a) in permanent stamping (stamped on the foot ring or, when relevant, the valve guard or shroud):
 - 1) the letters "LPG ";
 - 2) the tare mass (TM), in kilograms;
 - 3) the applicable standard approved for use in South Africa (for example, SANS 4706);
 - 4) the year of manufacture;
 - 5) the test pressure, in kilopascals;
 - 6) the water capacity, in litres; and
 - 7) the normalization symbol (N);
- b) in printed markings (applied by permanent labelling on all privately owned containers, i.e. containers of capacity 9 kg and less):
 - 1) a warning that the container shall not be placed on stoves or hot plates and shall be used in the upright position; and
 - 2) the maximum mass of gas, in kilograms, that the container is allowed to contain.

Where the label is missing or illegible, ensure that it is replaced.

9.1.2 Damaged containers

Before any container is filled, check it visually for defects. The following are regarded as defects:

- a) corrosion/pitting;
- b) illegible stamping;
- c) a container that was manufactured before 1969 without the normalization symbol;

NOTE The requirement that containers had to be normalized only came into force as of 9 October 1969. Therefore, the Department of Labour directed (refer circular letter ref. 34/2/12/1/1 dated 1991-10-18) that all such containers manufactured before that date had to be taken out of circulation, inspected and normalized before being refilled. After being normalized, they had to be stamped with the symbol, N, and the date of normalization in order to comply with the requirements of SANS 10019.

- d) fire damage;
- e) cutting/gouging;
- f) defective fittings;
- g) unacceptable modifications;
- h) bulging/denting;
- i) delamination; and
- j) presence of arc/torch burns.

Fill only physically sound containers. Mark damaged and rejected containers as such and withhold them from circulation for later removal. Ensure that scrapping of containers is done in accordance with SANS 10019 and SANS 1825.

9.1.3 Valve protection

Protect protruding valves on containers with permanent, fixed collars or screw-type protective caps, valve guards or shrouds.

9.1.4 Foot rings

Ensure that container foot rings are in a serviceable condition.

9.1.5 Operation of valves

Check each valve in the following way to ensure that it is still in good operating condition:

- a) operate the valve to ensure that it is not too tight to operate, and that it is undamaged and operable;
- b) ensure that the valve outlet threads are clean and undamaged;
- c) ensure that the valve or the valve boss is not tilted;
- d) ensure that there are no cracks or flaws in the container neck; and
- e) ensure that the safety-relief valve, if fitted, is free of damage, corrosion, plugging or any other condition that might impair its operation.

9.1.6 Replacement of components

Replacement of any faulty component shall be conducted by a competent person or the container shall be returned to its owner with appropriate advice.

9.2 Inspection after filling with LPG

9.2.1 After filling, check each container by weighing to ensure that it is still within the appropriate mass tolerance.

SANS 10087-7:2013

Edition 4

9.2.2 Examine all containers for leaks in the fully closed position, either by painting soapy water over the valve connection on the container or the suspected area and watching for any signs of bubbling, or by any other acceptable means.

9.2.3 If an overfilled container is found, immediately transfer the excess liquid contents to another container in the filling area.

9.2.4 If a valve leak is detected, immediately empty the container by transferring the liquid contents to another container and by venting any remaining LPG into the atmosphere, as follows:

- a) Ensure that a competent person is present, and responsible for the entire venting procedure. This person shall ensure that no source of ignition is brought into the area and that the speed of venting is controlled.
- b) Take wind direction into consideration and carry out the venting procedure in such a way that any prevailing wind will tend to dissipate the escaping gas away from any possible source of ignition.
- c) Keep water (supplied by means of a fire hose reel) or a dry chemical powder fire extinguisher (of capacity at least 9 kg) at hand during the venting procedure.

NOTE For the appropriate action in case of a fire, see clause 12.

- d) Open the container valve and allow the gas to escape slowly and to disperse into the air without causing a hazardous concentration of gas. Keep the container in a vertical position. Avoid inhaling the gas. When the container is empty, close the valve securely and return it to its owner (see also 7.2).

9.3 Details to be displayed on a container after filling

Each privately owned container that was filled shall bear the following information on a self-adhesive durable label:

- a) the date it was filled;
- b) the name of the dealer; and
- c) the filled mass.

NOTE The filled mass of the container is the tare mass of the cylinder plus that of the gas content.

10 Filling procedure

10.1 Filling by mass measurement

Ensure that the total mass of the container after filling is equal to the tare mass stamped on the container plus the mass of LPG (appropriate to the size of the container) that the container is permitted to hold, subject to a tolerance of $\begin{matrix} +2 \\ -3 \end{matrix}$ %.

In cases where automatic mass measurement is not available, qualified operators shall ensure that containers are filled accurately by continuously observing the scale during filling.

10.2 Operation of valves

Do not use a spanner or tool of any sort to open and close hand-operated valves. Where a special purpose-made handle for opening and closing particular valves is provided by the manufacturer, use only the handle provided.

10.3 Overfilling

Do not overfill containers. If a container has been overfilled, discharge or vent the excess gas in a safe and effective way in the filling area (see 9.2.3).

11 Handling and storage of LPG containers

11.1 Handling of LPG containers

NOTE See also clause 7.

11.1.1 Containers shall be handled with care and shall not be subjected to shock. Care shall be taken to avoid any damage to the container and the valve.

11.1.2 Containers shall not be dropped (for example, from lorry tailboards), dragged or rolled on their sides or allowed to skid. Containers that are too large to be carried shall be tilted and rolled on the rims of their foot rings. Containers that cannot be handled by hand, shall be transported by hand trolley.

11.1.3 Filled containers shall always be handled, transported, used and stored in a secured, upright position except for containers that are designed to be handled, transported, used and stored in the horizontal position.

11.1.4 All containers that are empty (or appear to be empty) shall be handled with the same care as a full container, and the distributing plant operator shall ensure that the valves of all empty containers received for filling are closed properly.

11.2 Storage of LPG containers

11.2.1 Storage area

The storage area shall

- a) be approved and be as shown in figures 3 to 11;
- b) not be located inside a building, but in an open, well-ventilated area, and shall be used exclusively for the storage of LPG containers,
- c) be so located as to eliminate, as far as possible, exposure of the containers to any excessive rise in temperature, corrosive substances or vapours, other highly flammable substances, physical damage and tampering by unauthorized persons,
- d) be kept clean and free from any accumulation of combustible matter, such as paper. Any possible source of ignition shall not be allowed in a storage area. An area of at least 3 m in all directions round the perimeter of the storage area shall be kept clear of grass, weeds and other combustible matter, including any electrical source of ignition that does not comply with the requirements of zone 2 equipment, and
- e) be provided with fire-fighting protection as given in table 1, and where this cannot be achieved, a rational design as given in SANS 10400 shall be applied.

Purposely designed containers/structures shall be acceptable, provided that the requirements of 5.2 are complied with.

SANS 10087-7:2013

Edition 4

All potentially dangerous activities, such as the use of open flames, welding and cutting operations, the use of electric grinding tools, and smoking, shall be prohibited in the storage area, and symbolic safety signs as described in 5.13 shall be permanently displayed.

Table 1 — Summary of fire protection details

1	2
Installation capacity kg	Fire precautions
0 – 500	1 × 9 kg dry powder extinguisher
501 – 2 250	Water supply for fire brigade use – within 100 m 2 × 9 kg dry powder extinguishers
2 251 – 9 000	Water supply for fire brigade use – within 100 m 20 mm hose reel 2 × 9 kg dry powder extinguishers
9 001 – 45 000	Consideration shall be given to providing a means of applying cooling water to the storage area 20 mm hose reel 2 × 9 kg dry powder extinguishers
45 001 – 67 500	Fixed or portable monitors or fixed sprays (or a combination) 20 mm hose reel 2 × 9 kg dry powder extinguishers
> 67 500	Automatic fixed sprays and hydrant and hose 20 mm hose reel 2 × 9 kg dry powder extinguishers
Container filling area	20 mm hose reel 2 × 9 kg dry powder extinguishers

11.2.2 Electrical equipment

All electrical equipment and wiring in the storage area shall be suitable for zone 2 hazardous locations.

11.2.3 Conditions for storage

11.2.3.1 General

11.2.3.1.1 Containers that do not exceed 9 kg may be stacked (9 kg containers may only be stacked 2 high where as containers of 6 kg and less may be stacked 4 high), provided the container design caters for such stacking.

11.2.3.1.2 Containers may be stored on acceptable, robust shelves constructed of a non-combustible material.

11.2.3.1.3 Containers shall always be stored at or above ground level and at least 2 m away from openings to, for example, basements, drains, hollows or depressions, manholes and culverts where vapour might collect.

11.2.3.1.4 Containers storage areas shall have ventilation at floor level.

11.2.3.1.5 Containers shall be so stored that they are accessible for inspection at all times and that every container is readily removable.

11.2.3.1.6 Containers that are in storage (including empty containers) shall have their valves firmly closed.

WARNING Empty containers that are left open will admit air to form an ignitable mixture that can be very hazardous.

11.2.3.1.7 Containers that have not contained any LPG may be stacked in the horizontal position.

11.2.3.2 Conditions for storage capacity of less than 250 kg

Where containers are stored, they shall be enclosed in a storage cage. Such storage cage shall

- a) only be able to accommodate 250 kg of gas at any time;
- b) be constructed of non-flammable material, and the material and design shall not restrict the flow of cooling water onto the containers for fire-fighting purposes;
- c) not accommodate more than two rows of containers per level from the access point of the cage;
- d) be designed in such a manner that where it has a roof or shelving, it shall not allow for the storage of any other items, and such roof or shelving shall not interfere with the access to the container valves;
- e) be fixed and positioned in accordance with the safety distances as given in table 2;
- f) be located at least 1,5 m away from any electrical equipment that does not comply with zone 2 requirements; and
- g) be located in such a way that no vehicle shall get closer than 1 m from the cage (see table 2 column 3); where vehicles can get closer than the required distance, then fixed bollards or any other acceptable barriers, shall be fitted at the perimeter of the safety distance.

11.2.3.3 Conditions for storage capacity of more than 250 kg

11.2.3.3.1 Containers that are full shall be separated from containers that are empty, and both shall be stored in clearly demarcated areas, depicted by symbolic safety signs, which shall be a minimum of 190 mm × 190 mm.

11.2.3.3.2 Gangways shall be provided and shall be wide enough to allow easy access to, and handling of, individual containers. Containers shall not be stored in more than four rows between gangways. Where the rows of containers are placed directly adjacent to a fence or wall, there can only be two rows before the next gangway.

11.2.3.3.3 The storage area may have a roof, provided that it is of non-combustible construction and that it is at least 2,5 m above floor level.

11.2.3.3.4 The floor of the storage area shall be of concrete or other non-combustible and impervious material, and there shall be no spaces underneath it where leaking gas can collect and thus create a fire hazard.

11.2.3.3.5 If unauthorized persons can gain access to the storage area, the storage area should be enclosed by a wire mesh fence of height at least 1,8 m and that has an outward-opening gate that shall be kept locked when not in use.

11.2.3.3.6 The fence supports should be of steel or reinforced concrete. If the floor area exceeds 10 m², an additional escape gate, fitted with a sliding bolt or other similar locking device that can be opened from the inside without using a key, shall be provided. The second gate shall be fitted as far as possible from the first.

11.2.3.3.7 Where storage of containers exceeds a total quantity of 3 000 kg, additional gates shall be fitted to ensure safe evacuation (see 11.2.3.3.6).

SANS 10087-7:2013

Edition 4

11.2.3.3.8 Only electrical equipment that complies with the minimum zone 2 requirements of SANS 10086-1 shall be installed in the storage area.

11.2.4 Storage of containers within a combined storage and filling area

The storage area shall

- a) be approved and be as shown in figures 3 to 5,
- b) be at least 3 m from the filling point,
- c) not be less than the filling area, and
- d) at least comply with the requirements of zone 1 and zone 2 for electrical equipment.

Where a filling point and storage area are combined, the filling area shall comply with the requirements of zone 1, and the storage area shall comply with the requirements of zone 2.

Containers in a combined storage and filling area shall not exceed a total of 1 500 kg, with a maximum of 500 kg allowed in the filling area and a maximum capacity of 1 000 kg in the storage area (see figures 3 to 5). For combined storage and filling area exceeding 1 500 kg refer to SANS 10087-3.

Figures 6 and 7 exclude a storage area.

Figures 8 to 11 show storage that exceeds 1 000 kg.

11.2.5 Safety distance requirements

11.2.5.1 Vapour barriers or firewalls, as appropriate, can be used to reduce the distances given in table 2. However, the presence of vapour barriers and firewalls can create significant hazards, for example, pocketing of escaping gas, interference with the application of cooling water by the Fire Department, redirection of flames against storage vessels, and impeding the movement of personnel in an emergency.

11.2.5.2 Special care shall be taken to ensure that where two walls are joined to form an enclosing corner, the angle shall be not less than 90°.

11.2.5.3 Safety distances shall be measured horizontally from the perimeter of the storage area where vapour barriers are used. The distance shall be measured in a horizontal line around such barriers. Safety distances shall be measured horizontally and radially from the perimeter of the storage area where firewalls are used.

11.2.5.4 The minimum safety distances from buildings, boundaries of premises, thoroughfares, sidewalks and the line of adjoining properties, schools or places of worship, etc. shall be in accordance with the requirements of table 2.

11.2.5.5 The safety distances given in table 2 shall be applicable to open storage areas only. Where containers are to be installed within a shipping container, the safety distances given in SANS 10400 shall apply.

11.2.5.6 The minimum horizontal separation distance between above-ground LPG storage area perimeters and above-ground storage vessels containing liquids that have flash points below 93,4 °C, shall be 6 m.

11.2.5.7 The minimum horizontal separation distance between LPG storage area perimeters and above-ground storage vessels containing other flammable gases and flammable liquids shall be 7,5 m.

11.2.5.8 Where a firewall with a minimum fire resistance rating of 240 min interrupts the line of sight between un-insulated portions of flammable compressed gases, for example in the case of acetylene, hydrogen and LPG containers, the minimum safety distances measured around the wall shall apply (see table 2).

Table 2 — Minimum safety distances

1	2	3
Total quantity of LPG stored Kg	Minimum distance M	
	From buildings and boundary of the premises	From thoroughfares, sidewalks and line of adjoining property of school, places of worship, etc.
< 250	1,0	1,0
250 – 500	1,5	3,0
501 – 1 000	3,0	5,0
1 001 – 3 000	5,0	5,0
3 001 – 5 000	7,5	7,5
5 001 – 20 000	10,0	10,0
> 20 001	15,0	15,0

11.2.5.9 Vehicles that are not equipped with normal aspirated diesel engines or not specifically designed and adapted for operation in flammable atmospheres, shall be prohibited from entering a storage area and shall not get closer than 5 m from the boundary of such storage area.

11.2.5.10 No part of an LPG container storage area shall be located 1,8 m horizontally from a vertical plane beneath overhead electric power lines of over 600 V.

11.2.5.11 LPG storage for LPG containers and other liquefied flammable gases of more than 50 kg total capacity shall have a minimum separation distance of 7,5 m.

12 Prevention and control of fires involving LPG

12.1 General

LPG vapours become flammable when mixed with air. Severe fires and explosions can result when such mixtures ignite. The following information is given as a guide to users of LPG:

- a) A liquid leak from an LPG container will generate a very large volume of gas vapour. Liquid leaks are therefore a much greater source of hazard than vapour leaks.
- b) LPG vapours do not disperse easily and, being heavier than air, will hug ground contours and will tend to flow along natural paths and fill depressions, ditches and pits. In favourable conditions, flammable vapours can travel for long distances from the point of release. They might also enter a building and be contained there, particularly in basements and cellars. Vapour dispersal can be accelerated by water spray or wind.

SANS 10087-7:2013

Edition 4

- c) Small fires involving LPG can usually be readily extinguished by dry-chemical-type fire extinguishers. Such extinguishers shall be installed at the filling and storage area.
- d) Empty containers that are left open will admit air. In this way an ignitable mixture that can be very hazardous is formed.
- e) The requirements for sites where LPG gas are stored are specified in table 1.

12.2 Gas leakage

If a leak develops

- a) close the supply valve on the container or emergency shut off valve and take remedial action (see 12.3); or
- b) immediately inform both the local fire authority and the supplier if the leak cannot be stopped.

12.3 Action in an emergency

12.3.1 Gas leakage without fire

Unless remedial action, such as closing the valve, can be effected on the spot, a leaking container shall be identified and handled as described in 9.2.4.

12.3.2 Gas leakage with fire

12.3.2.1 In the event of a fire, it is the responsibility of the first respondent or owner or person in charge to ensure that the fire department is immediately informed, before attempting to extinguish any flames.

Unless there is a danger that flames might impinge on other containers, no attempt shall be made to extinguish a fire before the source of the leakage has been determined and it is known that the leakage can be stopped after the fire has been extinguished. For example, a fire occurring at the outlet of a container valve can be extinguished by means of a portable extinguisher, provided that the valve is then closed immediately or the container is promptly removed to the filling point or a place where gas leakage will not result in a subsequent explosion.

12.3.2.2 Where it is not possible to extinguish the fire and either to stop the leakage or to remove the leaking container promptly, water spray shall be used to keep cool all the containers in the vicinity of the burning fire.

12.3.3 Containers exposed to fire

12.3.3.1 If a container that does not incorporate a safety-relief device is exposed to severe heat radiation, acceptable volumes of water sprayed onto the container will cool the liquid and will, in all probability, prevent hydraulic rupturing that could result from over-pressurization. Nevertheless, an assessment shall be made of the risks of possible rupture since such rupture occurs with explosive force and can endanger life and property over a considerable area. The impingement of flames on containers shall be regarded as an extremely dangerous condition that necessitates immediate evacuation of the area.

NOTE Evacuation distances will depend on the total volume of gas involved. Evacuation distances of up to 600 m should be considered.

12.3.3.2 Containers not involved in or affected by the fire shall be removed to a safe area or, alternatively, if this is not possible, such containers shall be kept cool by spraying them gently with acceptable quantities of water. If containers equipped with relief devices are exposed to a severe

SANS 10087-7:2013

Edition 4

fire, care shall be taken to avoid jets of gas that escape via these devices (for example, by standing well clear of the containers), since such jets might extend as far as 10 m.

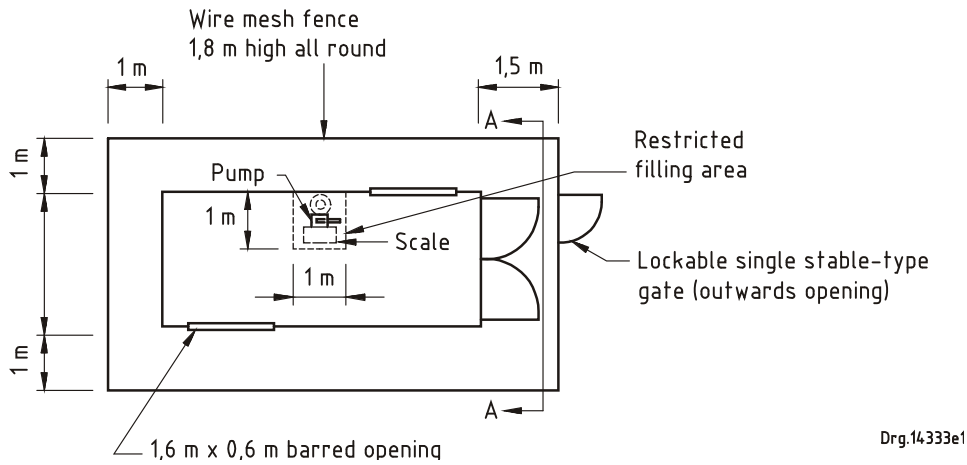

a) Plan view

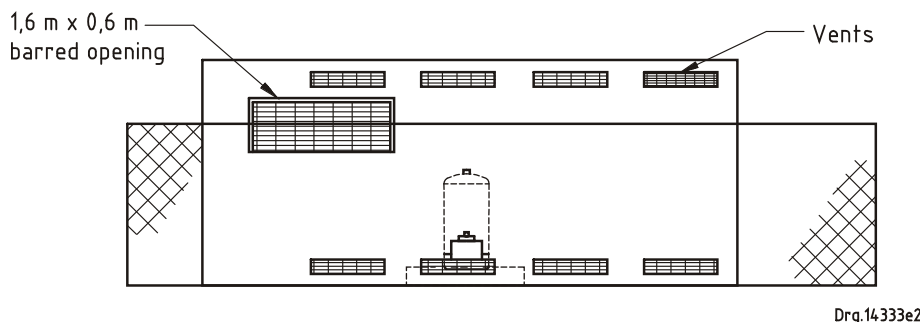

b) Side elevation

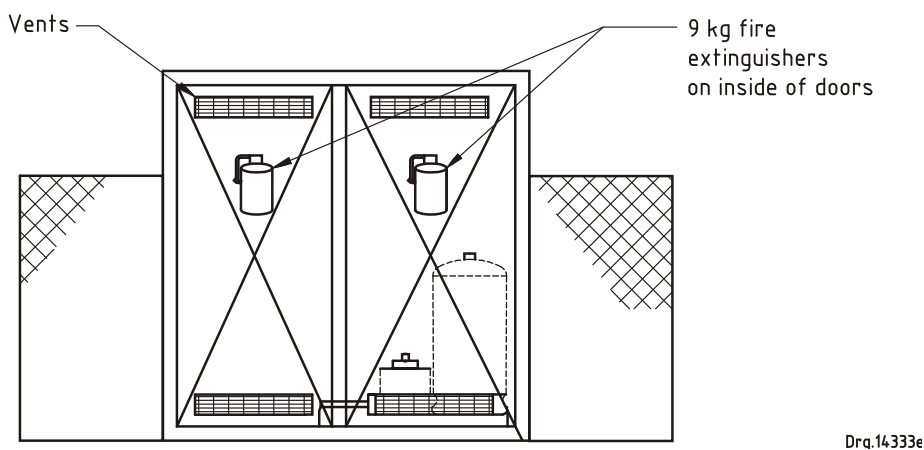

c) End elevation (section A-A)

NOTE This figure shows a filling site. However, the same principle may be used where a shipping container is only required for storage of gas containers. This storage is limited to 500 kg of gas per shipping container.

Figure 1 — Typical purpose-designed filling or storage container

SANS 10087-7:2013
Edition 4

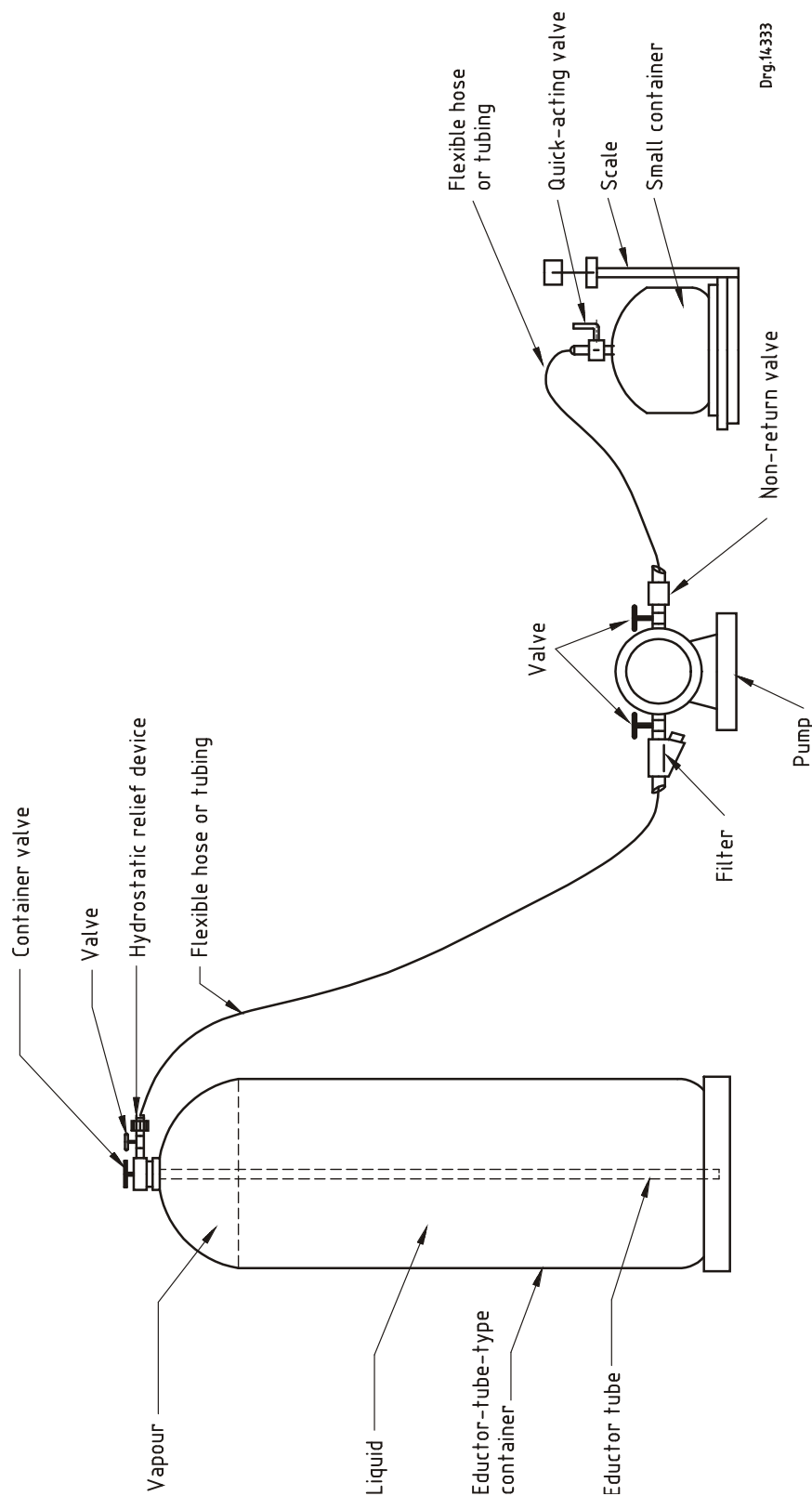

Figure 2 — Filling equipment

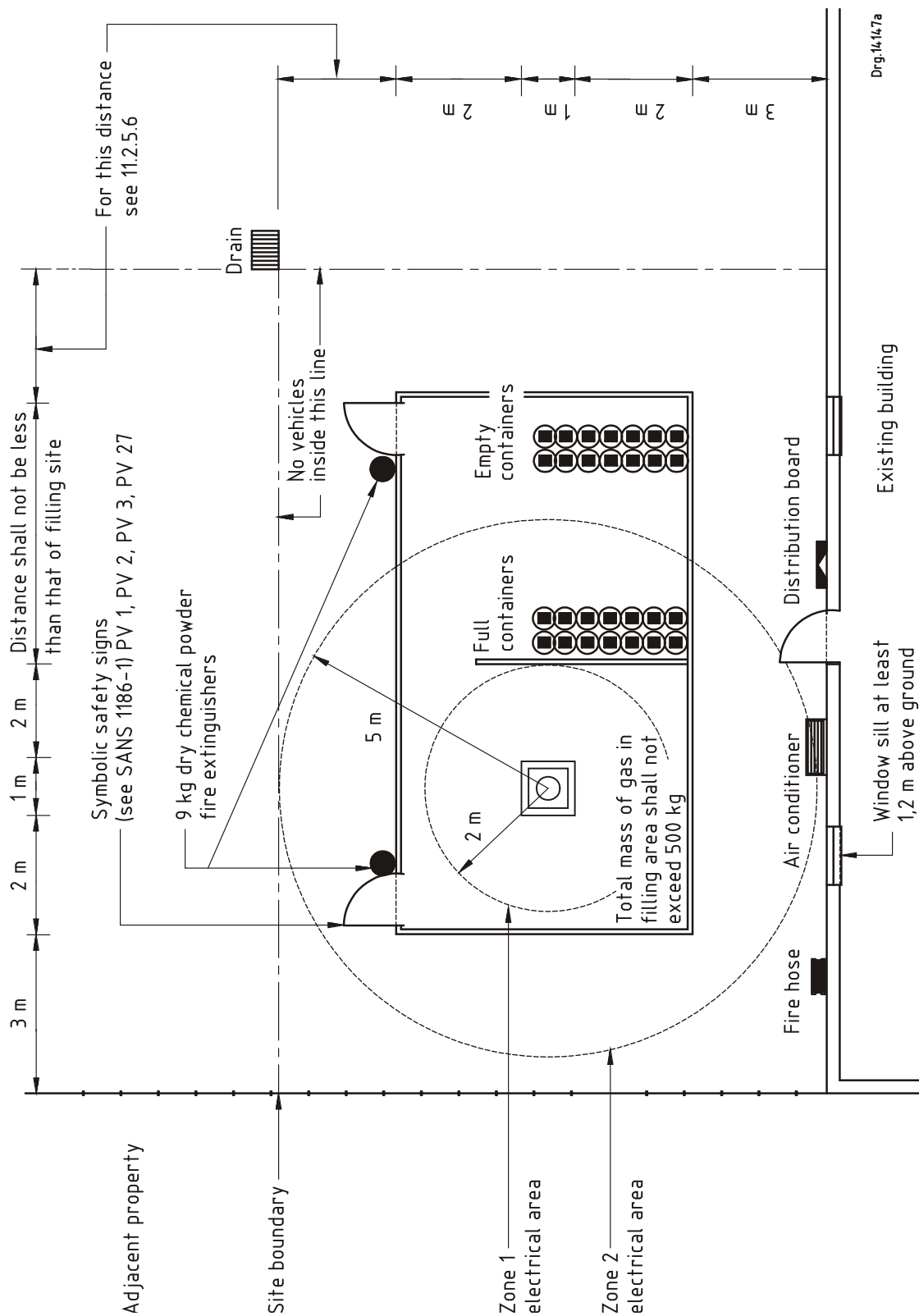

Figure 3 — Combined filling area and storage area for LPG containers

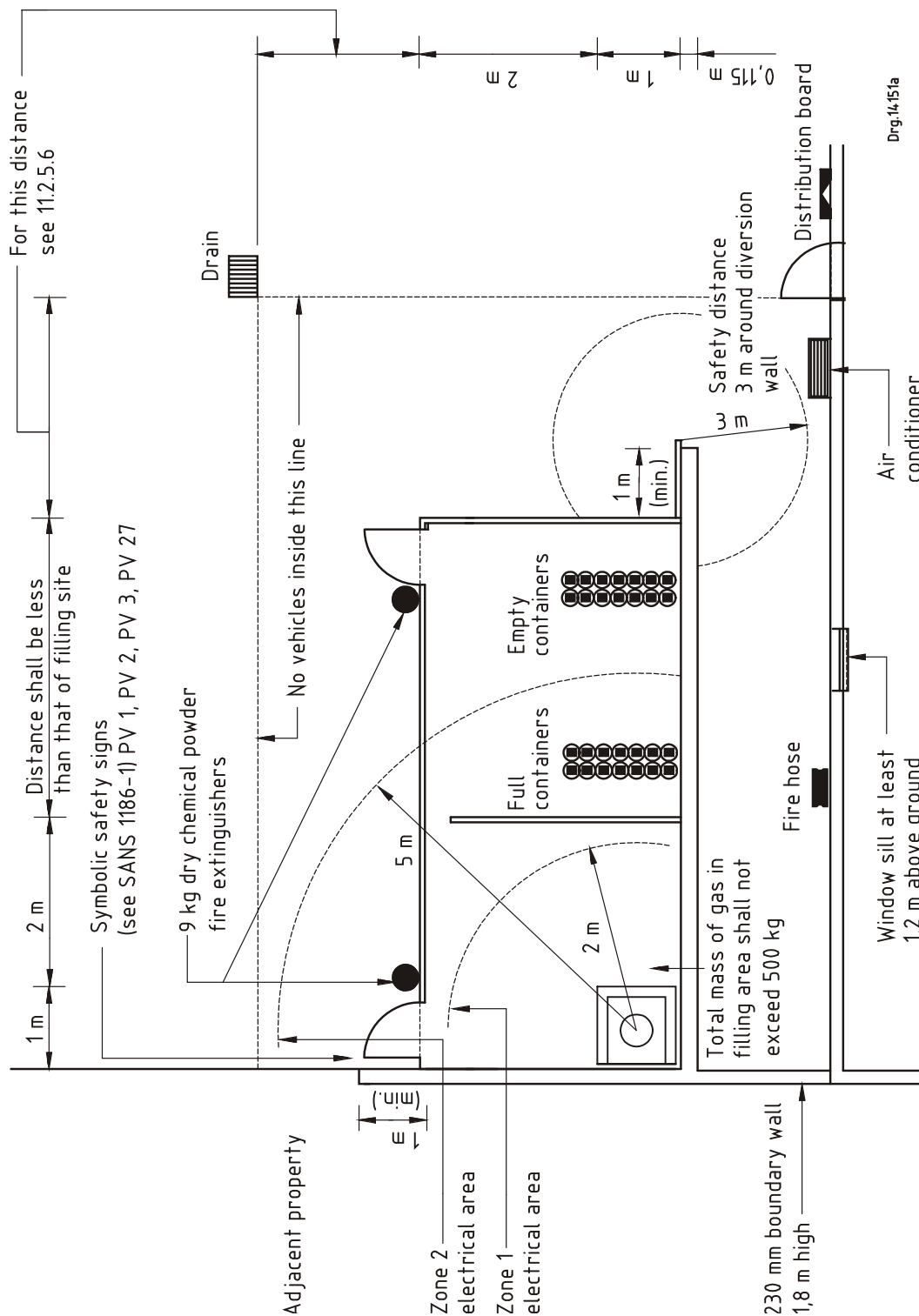

Figure 5 — Combined filling area and storage area for LPG containers (against diversion wall)

SANS 10087-7:2013
Edition 4

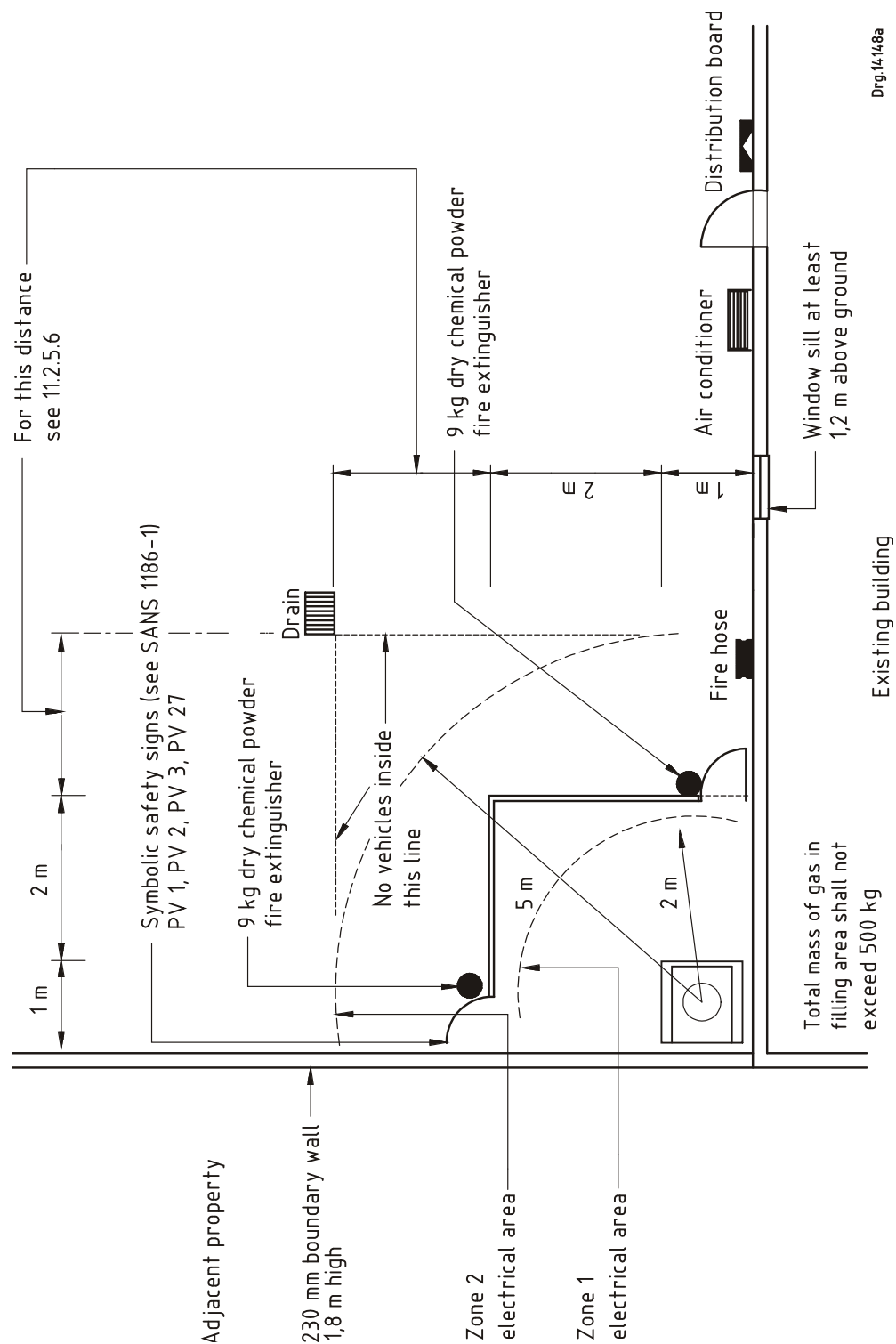

Figure 6 — Filling area for LPG containers (against boundary wall and excluding storage area)

SANS 10087-7:2013

Edition 4

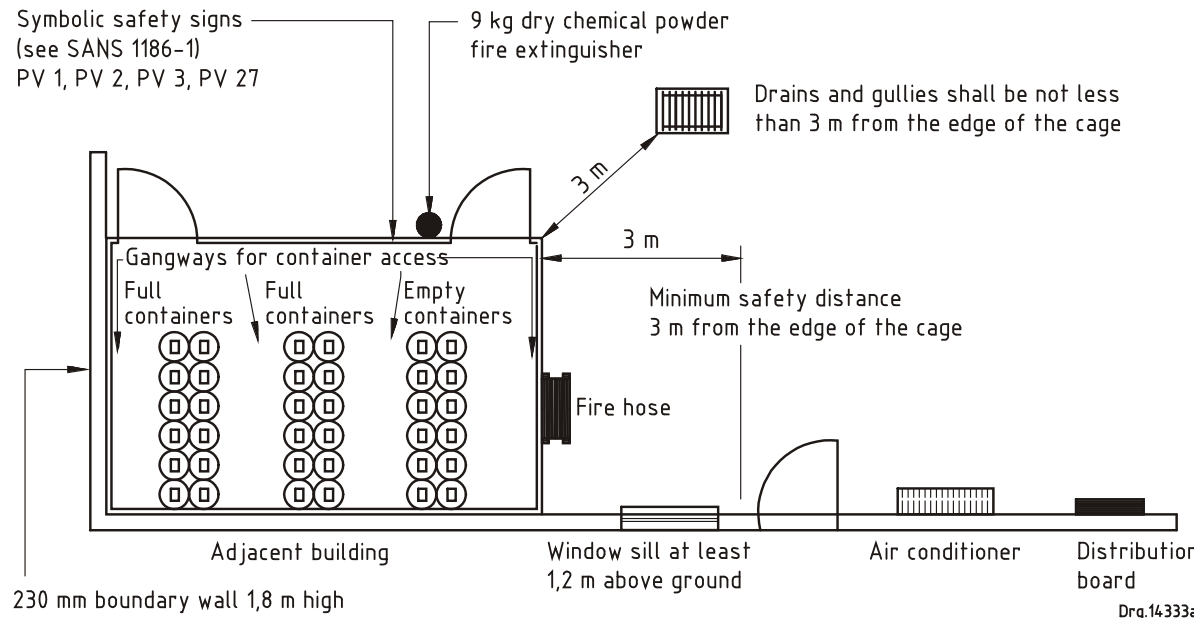

Figure 8 — Storage cage for LPG containers (against adjacent boundary and adjacent building walls (or both))

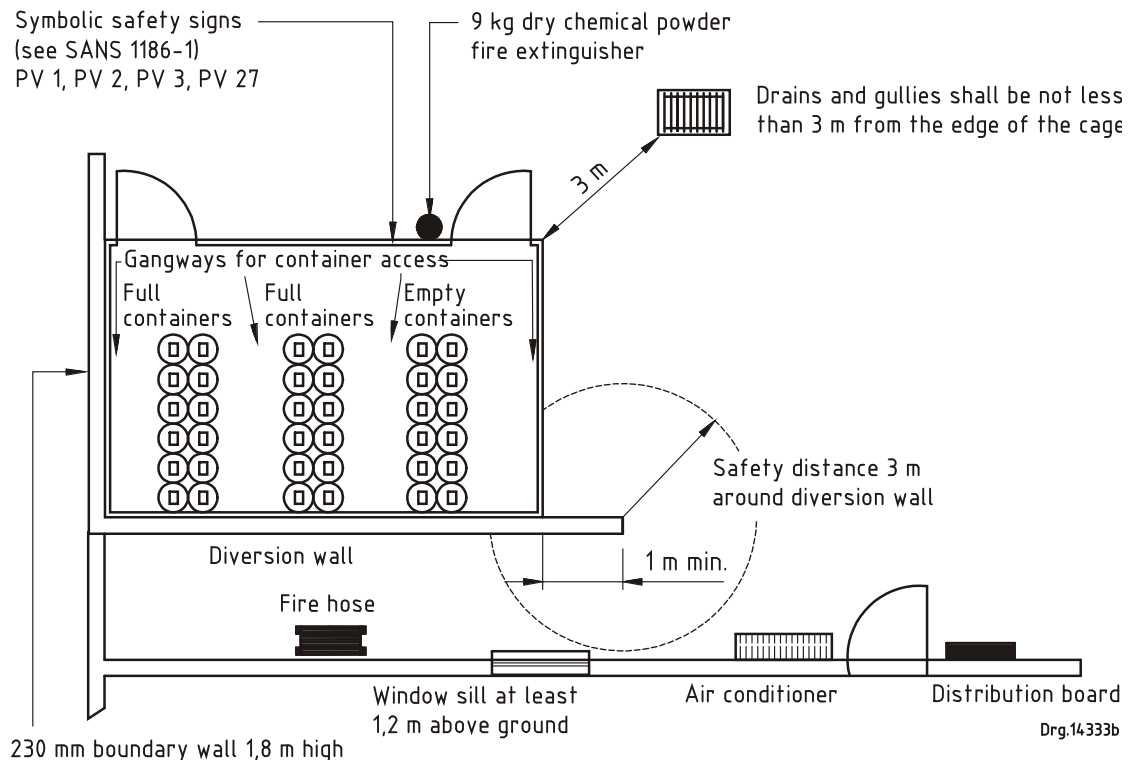

Figure 9 — Storage cage for LPG containers (against adjacent boundary and diversion walls)

SANS 10087-7:2013
Edition 4

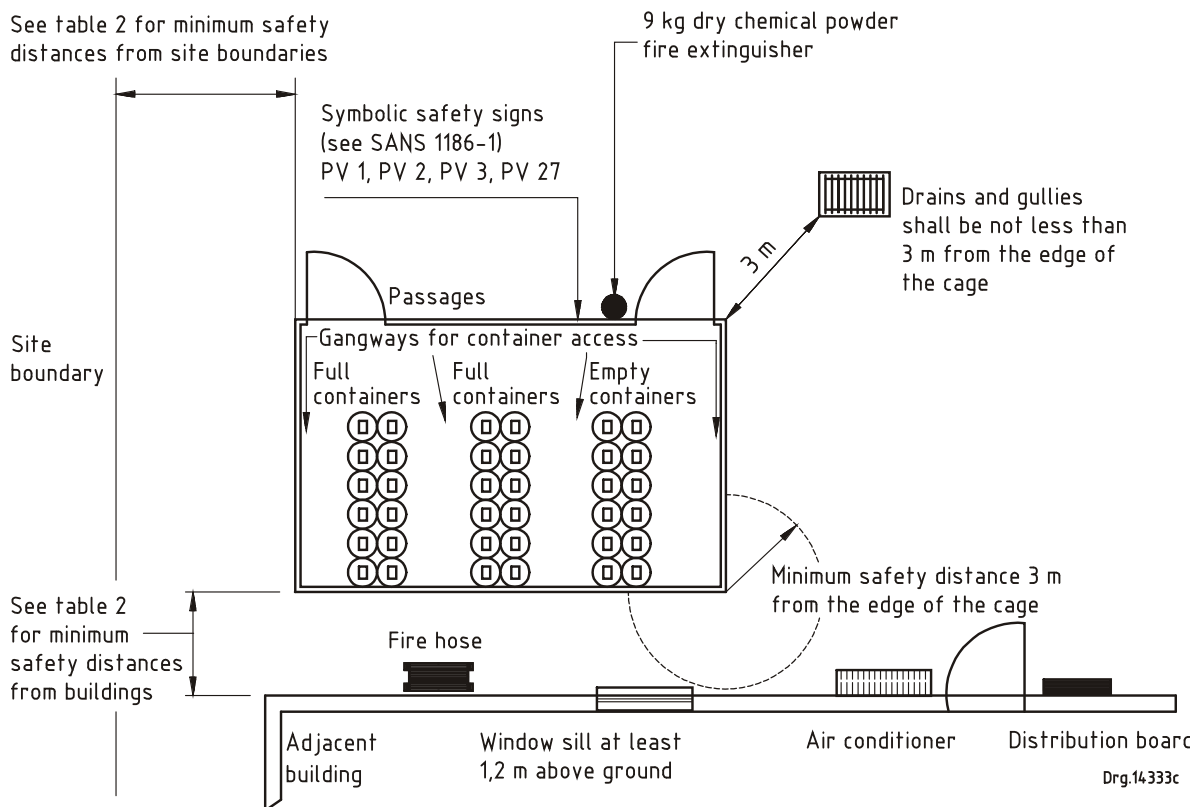
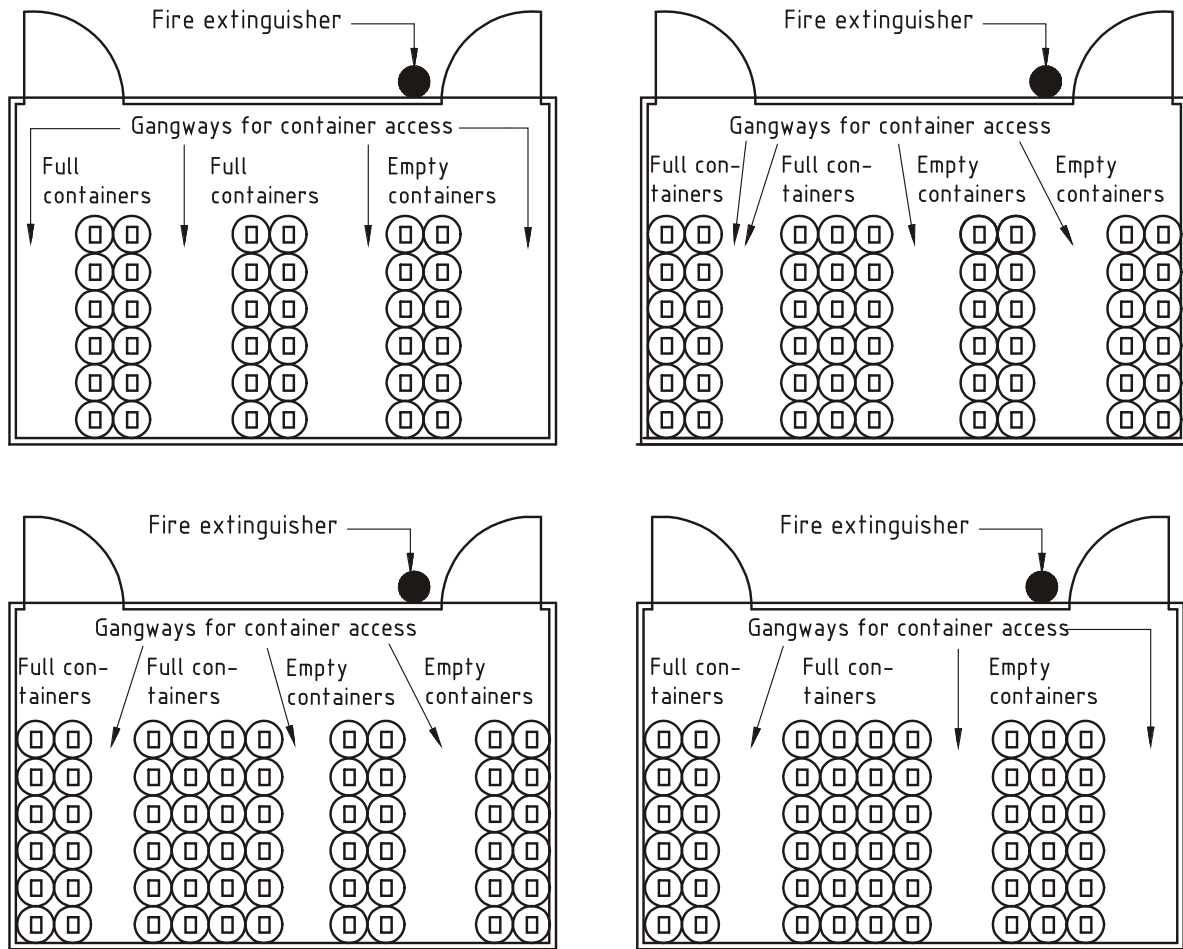

Figure 10 — Free-standing storage cage for LPG containers

SANS 10087-7:2013

Edition 4



Drq.14333d

Figure 11 — Alternative container bank layouts for storage cages

Bibliography

SANS 1774, *Liquefied petroleum gases*.

SANS 4706/ISO 4706, *Gas cylinders – Refillable welded steel cylinders – Test pressure 60 bar and below*.

SANS 10263-0, *The warehousing of dangerous goods – Part 0: General requirements*.

SANS 60079-1/IEC 60079-1, *Explosive atmospheres – Part 1: Equipment protection by flameproof enclosures "d"*.

This page has been left blank intentionally

SABS – Standards Division

The objective of the SABS Standards Division is to develop, promote and maintain South African National Standards. This objective is incorporated in the Standards Act, 2008 (Act No. 8 of 2008).

Amendments and Revisions

South African National Standards are updated by amendment or revision. Users of South African National Standards should ensure that they possess the latest amendments or editions.

The SABS continuously strives to improve the quality of its products and services and would therefore be grateful if anyone finding an inaccuracy or ambiguity while using this standard would inform the secretary of the technical committee responsible, the identity of which can be found in the foreword.

The SABS offers an individual notification service, which ensures that subscribers automatically receive notification regarding amendments and revisions to South African National Standards.
Tel: +27 (0) 12 428 6883 Fax: +27 (0) 12 428 6928 E-mail: sales@sabs.co.za

Buying Standards

Contact the Sales Office for South African and international standards, which are available in both electronic and hard copy format.

Tel: +27 (0) 12 428 6883 Fax: +27 (0) 12 428 6928 E-mail: sales@sabs.co.za

South African National Standards are also available online from the SABS website
<http://www.sabs.co.za>

Information on Standards

The Standards Information Centre provides a wide range of standards-related information on both national and international standards. The Centre also offers an individual updating service called INFOPLUS, which ensures that subscribers automatically receive notification regarding amendments to, and revisions of, international standards.

Tel: +27 (0) 12 428 7911 / 0861 27 7227 Fax: +27 (0) 12 428 6928 E-mail: info@sabs.co.za

Copyright

The copyright in a South African National Standard or any other publication published by the SABS Standards Division vests in the SABS or, in the case of a South African National Standard based on an international standard, in the organization from which the SABS adopted the standard under licence or membership agreement. In the latter case, the SABS has the obligation to protect such copyright. Unless exemption has been granted, no extract may be reproduced, stored in a retrieval system or transmitted in any form or by any means without prior written permission from the SABS Standards Division. This does not preclude the free use, in the course of implementing the standard, of necessary details such as symbols, and size, type or grade designations. If these details are to be used for any purpose other than implementation, prior written permission must be obtained.

Details and advice can be obtained from the Manager – Standards Sales and Information Services.
Tel: +27 (0) 12 428 6883 Fax: +27 (0) 12 428 6928 E-mail: sales@sabs.co.za