

ISBN 978-0-626-24856-7

SANS 10087-2:2011

Edition 3

SOUTH AFRICAN NATIONAL STANDARD

The handling, storage, distribution and maintenance of liquefied petroleum gas in domestic, commercial, and industrial installations

Part 2: Installation of LPG systems in mobile units, including but not limited to caravans, motor homes, park homes and mobile kitchens

Published by SABS Standards Division
1 Dr Lategan Road Groenkloof ☒ Private Bag X191 Pretoria 0001
Tel: +27 12 428 7911 Fax: +27 12 344 1568
www.sabs.co.za
© SABS

SABS

SANS 10087-2:2011

Edition 3

Table of changes

Change No.	Date	Scope

Foreword

This South African standard was approved by National Committee SABS TC 1019, *Gas supply, handling and control (Fuel and industrial gases)*, in accordance with procedures of the SABS Standards Division, in compliance with annex 3 of the WTO/TBT agreement.

This document was published in July 2011.

This document supersedes SABS 087-2:1977 (edition 2, reprint 1991).

This document was written in order to support a specific South African Regulation and, of necessity, includes references to South African legislation. It therefore might not be suitable for direct application in other jurisdictions where conflicting legislation exists.

Reference is made in 3.2.1 to "relevant national legislation". In South Africa this means the Trade Metrology Act, 1973 (Act No. 77 of 1973).

Reference is made in 3.2.2 to "relevant national legislation". In South Africa this means the Occupational Health and Safety Act, 1993 (Act No. 85 of 1993).

Reference is made in 3.2.4 to "relevant national legislation". In South Africa this means the Mine Health and Safety Act, 1996 (Act No. 29 of 1996).

Reference is made in clause 5 to "relevant national legislation". In South Africa this means the Road Vehicles (Construction and Use) Regulations.

Reference is made in 10.2.1(b) to "relevant national legislation". In South Africa this means the Pressure Equipment Regulations of the Occupational Health and Safety Act, 1993 (Act No. 85 of 1993).

Reference is made in 15.5 to "national legislation". In South Africa this means current Electrical Regulations.

SANS 10087 consists of the following parts, under the general title, *The handling, storage, distribution and maintenance of liquefied petroleum gas in domestic, commercial, and industrial installations*:

Part 1: Liquefied petroleum gas installations involving gas storage containers of individual water capacity not exceeding 500 L and a combined water capacity not exceeding 3 000 L per installation.

Part 2: Installation of LPG systems in mobile units, including but not limited to caravans, motor homes, park homes and mobile kitchens.

Part 3: Liquefied petroleum gas installations involving storage vessels of individual water capacity exceeding 500 L.

SANS 10087-2:2011

Edition 3

Foreword *(concluded)*

Part 4: The transportation of LP gas including the design, construction, inspection, fittings, filling, maintenance and repair of LP gas bulk vehicles and rail tank cars.

Part 6: The application of liquefied petroleum and compressed natural gases as engine fuels for internal combustion engines.

Part 7: Storage and filling premises for refillable liquefied petroleum gas (LPG) containers of gas capacity not exceeding 9 kg and the storage of individual gas containers not exceeding 48 kg.

Part 8: Filling containers for LP gas operated fork lift vehicles in-situ.

Part 10: Mobile filling stations for refillable liquefied petroleum gas (LPG) containers of capacity not exceeding 9 kg.

Annex C forms an integral part of this document. Annexes A and B are for information only.

SANS 10087-2:2011

Edition 3

Contents

	Page
Foreword	1
1 Scope	3
2 Normative references	3
3 Definitions	5
4 Properties of LPG	8
5 Vehicle design and construction	9
6 LPG containers and container valves	9
7 Inspection, testing, and instructions to users	17
8 Appliance installation	18
9 Instructions to users	20
10 Mobile kitchens	21
11 Gas installation pipework	22
12 Pressure regulators, automatic changeover devices and pigtails	23
13 Appliances	25
14 Ventilation and flues	26
15 Electric generators fuelled by LPG	27
16 Maintenance	27
17 Training and instruction	27
18 Fire precautions	27
19 Displayed safety instructions	28
20 Parking during use	29
Annex A (informative) Testing of the high-pressure stage of an installation	30
Annex B (informative) Testing of the low-pressure stage (as a whole) of an installation by U-gauge	31
Annex C (normative) Installations in mobile units	33

The handling, storage, distribution and maintenance of liquefied petroleum gas in domestic, commercial, and industrial installations

Part 2:

Installation of LPG systems in mobile units, including but not limited to caravans, motor homes, park homes and mobile kitchens

1 Scope

1.1 This part of SANS 10087 gives the installation requirements, materials, method of construction and the installation of the equipment used in liquefied petroleum gas applications for mobile units, including but not limited to caravans, motor homes, park homes, mobile kitchens, trailers and semi-trailers. It also includes the safety requirements for gas on recreation vehicles and mobile ablution facilities.

1.2 It also covers the requirements for mobile field kitchens and any other mobile units operating on LPG liquid withdrawal systems.

1.3 It also covers the requirements for inspection, test and maintenance of the various components and equipment used.

1.4 Where the container installation does not form a part of the mobile unit and is placed on the ground outside of the unit, then the container placement requirements of SANS 10087-1 shall apply and the rest of the installation shall comply with this standard.

1.5 It excludes the requirements for motor vehicles powered by LP gas and mobile units used for filling purposes which can be found in SANS 10087-6 and SANS 10087-10 respectively.

2 Normative references

The following referenced documents are indispensable for the application of this document. For dated references, only the edition cited applies. For undated references, the latest edition of the referenced document (including any amendments) applies. Information on currently valid national and international standards can be obtained from the SABS Standards Division.

ANSI/CSA LC 1a, *Fuel gas piping systems using corrugated stainless steel tubing (CSST)*.

AS 4176, *Polyethylene/aluminium and cross-linked polyethylene/aluminium macro-composite pipe systems for pressure applications*.

SANS 10087-2:2011

Edition 3

BS 669-1, *Flexible hoses, end fittings and sockets for gas burning appliances – Part 1: Specification for strip-wound metallic flexible hoses, covers, end fittings and sockets for domestic appliances burning 1st and 2nd family gases.*

BS 3212, *Specification for flexible rubber tubing, rubber hose and rubber hose assemblies for use in LPG vapour phase and LPG/air installations.*

BS 5292, *Specification for jointing materials and compounds for installations using water, low-pressure steam or 1st, 2nd and 3rd family gases.*

BS 5440-1, *Flueing and ventilation for gas appliances of rated input not exceeding 70 kW net (1st, 2nd and 3rd family gases) – Specification for installation of gas appliances to chimneys and for maintenance of chimneys.*

BS 7838, *Specification for corrugated stainless steel semi-rigid pipe and associated fittings for low-pressure gas pipework of up to DN 50.*

EN 853, *Rubber hoses and hose assemblies – Wire braid reinforced hydraulic type – Specification.*

EN 15266, *Stainless steel pliable corrugated tubing kits in buildings for gas with an operating pressure up to 0,5 bar.*

SANS 24, *Soft solders.*

SANS 199, *Shut-off valves for refillable liquefied petroleum gas cylinders.*

SANS 460, *Plain-ended solid drawn copper tubes for potable water.*

SANS 1067-1, *Copper-based fittings for copper tubes – Part 1: Compression fittings.*

SANS 1067-2, *Copper-based fittings for copper tubes – Part 2: Capillary solder fittings.*

SANS 1109-1/ISO 7-1, *Pipe threads where pressure-tight joints are made on the threads – Part 1: Dimensions, tolerances and designation.*

SANS 1156-2, *Hose for liquefied petroleum gas (LPG) – Part 2: Hose and tubing for use in LPG vapour phase and LPG-air installations.*

SANS 1186-1, *Symbolic safety signs – Part 1: Standard signs and general requirements.*

SANS 1237, *Single-stage regulators for liquefied petroleum gas (LPG).*

SANS 1306-1/ISO 228-1, *Pipe threads where pressure-tight joints are not made on the threads – Part 1: Dimensions, tolerances and designation.*

SANS 1475-1, *The production of reconditioned fire-fighting equipment – Part 1: Portable and wheeled (mobile) rechargeable fire extinguishers.*

SANS 1539, *Appliances operating on liquefied petroleum gas – Safety aspects.*

SANS 1774, *Liquefied petroleum gases.*

SANS 1850, *The design and manufacture of commercial kitchen extraction systems.*

SANS 1910, *Portable refillable fire extinguishers.*

SANS 10019, *Transportable metal containers for compressed, dissolved and liquefied gases – Basic design, manufacture, use and maintenance.*

SANS 10087-2:2011

Edition 3

SANS 10087-1, *The handling, storage, distribution and maintenance of liquefied petroleum gas in domestic, commercial, and industrial installations – Part 1: Liquefied petroleum gas installations involving gas storage containers of individual water capacity not exceeding 500 L and a combined water capacity not exceeding 3 000 L per installation.*

SANS 10087-6, *The handling, storage, distribution and maintenance of liquefied petroleum gas in domestic, commercial, and industrial installations – Part 6: The application of liquefied petroleum and compressed natural gases as engine fuels for internal combustion engines.*

SANS 10400 (SABS 0400), *The application of the National Building Regulations.*

SANS 17484-1/ISO 17484-1, *Plastics piping systems – Multilayer pipe systems for indoor gas installations with a maximum operating pressure up to and including 5 bar (500 kPa) – Part 1: Specifications for systems.*

3 Definitions

For the purposes of this document, the following definitions apply.

3.1

approved

approved by the approving authority

3.2

approving authority

the appropriate of the following:

3.2.1

within the scope of the relevant national legislation (see foreword); and in respect of the control of the mass of gas sold: the Director of Trade Metrology;

3.2.2

within the scope of the relevant national legislation (see foreword); and in respect of the control of general safety: the Chief Inspector;

3.2.3

within the scope of SANS 10400 and in respect of the evaluation and control of installations in accordance with this part of SANS 10087: the local authority in whose area of jurisdiction the installation is installed; and

3.2.4

within the scope of the relevant national legislation (see foreword) and in respect of the control of the general safety: the Chief Inspector

3.3

assembly

system that includes connection by pipe or similar ducts, fittings and valves which operate under gauge pressure and are used for the conveyance of liquid or vapour

3.4

atmosphere sensing device

system which causes the gas supply to be shut off before the oxygen in the ambient air falls below a specified concentration

3.5

automatic changeover valve

device (used with LPG cylinders) which maintains continuity of gas supply by automatically switching supply from empty to full cylinders

SANS 10087-2:2011

Edition 3

3.6

caravan

small non-permanent dwelling that is used for domestic or recreational purpose and can be towed by a vehicle

3.7

competent person

person having the knowledge, training and experience specific to the work or task being performed

3.8

container

container that complies with SANS 10019 and that is approved for the storage and conveyance of liquefied petroleum gas and of individual water capacity not exceeding 500 L

3.9

critical location

area that is not ventilated for the dispersal of LPG

3.10

equipment

combination of pipes, pipe fittings, appliances and any appurtenances connected to the system

3.11

fixed appliance

appliance that is permanently mounted into a fixture, for example a stove or a fireplace

3.12

flame supervision device

device which will allow gas to flow to the burner of an appliance only while a flame exists, loss of flame will close the gas valve

3.13

flueless appliance

installed appliance where there is no flue to remove combustion emissions

3.14

gas equipment

gas equipment includes but is not limited to appliances, regulators, hose, piping, fittings or any other related gas component

3.15

installation

combination of one or more containers connected to a manifold system including pipework and appliances

3.16

liquefied petroleum gas

LPG

commercial butane, commercial propane, or a mixture of light hydrocarbons (predominantly propane, propene, butane and butene) that is gaseous under conditions of ambient temperatures and pressure, and that is liquefied by an increase of pressure or a lowering of temperature (see also SANS 1774)

3.17

location

position in which a container is kept or installed

6

3.18

manifold

where two or more containers are connected to each side of the changeover device

3.19

mobile appliance

unit that can be moved from one location to another, for example, a roll-about heater, a portable braai etc.

3.20

mobile field kitchen

vehicle or trailer that may be used with liquid withdrawal systems for commercial or industrial purposes

3.21

motor home

non-permanent dwelling that may be used for domestic or recreational purpose and is self-propelled

3.22

mobile kitchen

vehicle or trailer that may be used vapour withdrawal systems for commercial or industrial catering purposes

3.23

mobile unit

purpose built unit, that includes but is not limited to trailers, semi-trailers, caravans, motor homes, commercial catering units, recreation vehicles and mobile ablution facilities which accommodate various appliances for gas use

3.24

operating pressure

3.24.1

high pressure

pressure in excess of 150 kPa (gauge pressure)

3.24.2

intermediate pressure

pressure in excess of 5 kPa but not exceeding 150 kPa

3.24.3

low pressure

pressure not in excess of 5 kPa

3.25

open fixed appliance

appliance designed to be connected to a flue which incorporates a draught diverter open to the room or internal space in which the appliance is installed

3.26

park home

transportable unit that does not meet the requirements for construction and use of road vehicles, that retains means for mobility and is for temporary, seasonal or semi-permanent occupation and use

SANS 10087-2:2011

Edition 3

3.27

registered installer

person that has the ability, appropriate training, knowledge and experience to carry out the work that is undertaken in a safe and proper manner, and who is registered in accordance with the requirements of the department of labour

3.28

regulator

device for automatically maintaining a constant gas outlet pressure at the level recommended for the application

3.29

room sealed

appliance in operation that has the combustion air inlet and the combustion products outlet isolated from the room in which the appliance is installed

3.30

space heater

appliance for warming the interior of a room, vehicle or living space

3.31

user

person who uses the equipment for his own benefit or has the right of control over the use of the equipment, but does not include a lessor or any person employed in connection with that equipment

3.32

vehicle mounted tank

LPG container permanently secured to the vehicle and designed to be refilled in- situ

3.33

ventilation

free entry and circulation of air in a space such as a room

3.34

water heater

appliance for providing hot water e.g. an instantaneous heater without a hot-water tank, or a heater with hot water reservoir

4 Properties of LPG

Careful consideration should be given to the properties of the gas when the location of LPG containers and the construction of installations for conveying this gas in mobile units are allocated. It is therefore imperative that all persons concerned with the installation of containers and appliances into mobile units are qualified in this respect and are familiar with the precautions to be observed and the following characteristics of the gas:

- a) the gases are stored as liquids under pressure;
- b) leakage, especially of liquid, will release large volumes of highly flammable gases;
- c) a gas-air mixture that contains approximately 1,5 % to 10 % by volume of LPG is flammable. If a large enough volume of gas is so dispersed in the atmosphere as to reach flammable proportions throughout, ignition of the mixture will result in a rate of combustion of near-explosive force;
- d) LPG is denser than air, will flow along the ground and through drains, and can be ignited at a considerable distance from the source of leakage; low level ventilation of mobile units is therefore of utmost importance;

SANS 10087-2:2011

Edition 3

- e) LPG is non-toxic but, as it can induce headaches and dizziness when inhaled, inhaling the gas should be avoided whenever possible;
- f) LPG liquid can, by its rapid vaporization and consequent lowering of the temperature, cause severe cold burns when in contact with the skin. Protective clothing, such as gloves, goggles, aprons, and gumboots should be worn when there is any possibility of skin contact;
- g) a container that has held LPG and is presumed to be "empty" can be hazardous. In this state the internal pressure is approximately atmospheric and, if the valve leaks or is left open, air can diffuse into the container and form a flammable or explosive mixture. Further, an "empty" container that does not yield gas when the valve is opened might in fact not be quite empty. In cold weather the heavier fractions of the liquid might not vaporize and will remain in the container. All containers that are (or appear to be) empty should be handled with the same care as for a full container, and valves should be kept fully closed at all times when containers are not in use;
- h) the gas container shall always be used to prevent the accidental escape of liquid LPG and shall be transported in the vertical position unless it is specially designed to be used and transported in the horizontal position; and
- i) while in motion all gas equipment shall be shut-off. This requirement shall not apply to water craft or rail transport.

5 Vehicle design and construction

Vehicle design shall conform to the relevant national legislation (see foreword). If the vehicle is a trailer or caravan attention is drawn to the strict limitations on laden weight and nose weight specified by the manufacturer of the trailer and the towing vehicle.

6 LPG containers and container valves

6.1 Containers

6.1.1 All containers shall comply with the requirements of SANS 10019.

6.1.2 The number and the size of containers recommended for an LPG installation depend on the maximum hourly consumption of the appliances served and the lowest ambient temperature expected. Therefore the sizing of the system shall take into account the consumption of the appliance installed and the requirement of the gas supply needed. When an installation is designed, care should be taken to guard against possible failure of the gas supply due to vaporization problems.

One supply container and one reserve container of the same size are adequate for ordinary installations in mobile units. However, there are larger installations that require more gas, and the maximum gas off-take for these installations and the number of containers required can be calculated from tables 1 and 2.

6.1.3 Table 1 gives the approximate vaporization rates of the larger containers currently available.

SANS 10087-2:2011

Edition 3

Table 1 — Approximate vaporization rates for containers

1		2	
Nominal size of container		Approximate vaporization rates	
Water capacity	Nominal mass of gas	L/h	g/h
L	kg		
11	4,5	50	115
22	9	100	230
34	13 to 14	140	320
45	19	200	460
113	48	400	920

NOTE For the convenience of users of this part of SANS 10087, the LPG mass capacity equivalents for the various container sizes are also given in table 2. It should, however, be stressed that these are only nominal equivalents and that the exact mass equivalents will depend on the actual density of the product filled into the containers.

6.1.4 Table 2 gives, in terms of three of the more popular domestic-type container sizes, the approximate container requirements of some typical appliances, based on their gas consumption per hour and the vaporization rates for the containers. Use of this approach facilitates calculation of the containers required for a specific installation.

Table 2 — Container requirements of typical appliances

1	2	3	4	5	6
Appliance	Approximate number of containers required				Approximate input KJ/h
	Capacity of container				
	11 L (4,5 kg)	22 L (9 kg)	45 L (19 kg)	113 L (48 kg)	
Gas stove, normal domestic	3,00	1,50	0,65	0,32	42 000
Hotplate (2 burner)	2,00	1,00	0,25	0,12	16 000
Instantaneous water heater, multi-point	9,30	4,60	2,00	1,00	74 000
Instantaneous water heater, single-point	4,00	2,00	0,84	0,42	37 000
Gas light	0,20	0,10	0,04	0,02	2 000
Gas iron	0,40	0,20	0,8	0,04	3 000
Refrigerator	0,20	0,10	0,04	0,02	2 000
Space heater, small, portable type	0,80	0,40	0,16	0,08	5 000

NOTE 1 It has been found in practice that the approximations given above for 45 L (19 kg) containers can usually also be used for 34 L (13/14 kg) containers.

NOTE 2 The container requirements given above may be scaled down if it is unlikely that all appliances will be used simultaneously for long periods of time.

NOTE 3 Table 2 is based on results that are typical for cold-winter conditions in South Africa; in warmer conditions the requirements will be less. With experience, a registered installer will learn how the figures can be modified to suit local conditions.

6.1.5 The total requirements of an installation are obtained from the sum of the requirements of the individual appliances comprising the installation. For an installation consisting of a normal-sized stove, an instantaneous single-point water heater, a refrigerator, and eight gas lights, the container requirements are as given in table 3.

Table 3 — Typical container requirements for an installation

Appliance	2		
	Number of containers required		
	22 L (9 kg)	45 L (19 kg)	113 L (48 kg)
Gas stove, normal domestic	1,50	0,65	0,32
Instantaneous water heater, single-point	2,00	0,84	0,42
Refrigerator	0,10	0,04	0,02
Gas lights (8 × value given in table 2)	0,80	0,32	0,16
TOTAL	4,40	1,85	0,92

Any of the following would, therefore, be adequate:

- a) two 45 L (19 kg) containers coupled in parallel; or
- b) one 113 L (48 kg) container.

The best arrangement would be one 113 L (48 kg) container, with a second one in reserve where allowed for within the restrictions specified for a particular mobile unit.

6.2 Valves

Container valves shall comply with the requirements of SANS 199.

6.3 Container installation

6.3.1 General

The installation of a container(s) and all associated equipment and appliances and any subsequent repair or modifications to the installation shall be carried out by a registered installer qualified to the appropriate grade (domestic or commercial).

NOTE This requirement does not include the replacement of empty containers.

Container installation requirements for each type of mobile unit described in this part of SANS 10087 will be dealt with in the appropriate annex for that particular unit.

6.3.2 LPG container installation

The following precautionary measures shall be considered when installing LPG containers:

- a) LPG containers shall not be installed, inside any mobile unit. All LPG containers shall be installed upright in a compartment or recess vapour tight to the inside and safely vented to the outside atmosphere.
- b) Access to the gas containers shall only be from the outside. (See also 6.3.5.)

SANS 10087-2:2011

Edition 3

- c) Where the design of the unit is such that human occupancy is possible or needed to operate the appliance(s) within the unit the LPG containers shall be installed in a compartment or recess on the outside of a mobile unit and they shall be vapour tight to the inside of the mobile unit.
- d) Containers shall not be mounted on the rear bumper of the vehicle and if mounted on the rear wall of a mobile unit shall be mounted in such a way as to be outside of the impact zone if rammed from the back.
- e) Where containers incorporate pressure relief valves, containers shall be so located that the discharge from their pressure relief valves shall be not less than 1 m measured horizontally along the surface of the vehicle from any of the following located below the level of such discharge:
 - 1) openings into the vehicle;
 - 2) fuel-burning appliance intake and exhaust vents; or
 - 3) all internal combustion engine exhaust terminations.
- f) LPG containers shall not be installed in compartments or under hoods or housings that contain flame-or spark-producing equipment.

6.3.3 Securing of LPG containers

Containers in transit shall be secured in place so they do not become dislodged when a load equal to four times the container's filled weight is applied to the filled container's centre of gravity in any direction.

6.3.4 Container protection

Doors, hoods, domes, housings (or portions of housings), and enclosures, required to be removed or opened for replacement of cylinders, shall incorporate means for clamping them in place to prevent them from working loose during transit.

6.3.5 Container compartments

Compartments shall be ventilated to atmosphere at or near the top and at the extreme bottom to facilitate diffusion of vapours.

The compartment shall be ventilated with at least two vents having an aggregate free area equal to at least 1 cm² per 500 g of the total LPG fuel capacity of the maximum number of largest container(s) the compartment can hold.

The vents shall be equally distributed between the floor and ceiling of the compartment. If the lower vent is located in the access door or wall, the bottom edge of the vent shall be flush with the floor level of the compartment.

Vents situated in the floor of the compartment shall terminate at a point which faces away from the forward direction of travel. Vents in the floor shall be 1 m away from any opening into the mobile unit unless the opening is 150 mm above the level of the vent; and at least 1,5 m from any source of ignition unless the ignition is at least 500 mm above the level of the vent.

The top vent shall be located in the access door or wall with the bottom of the vent within 300 mm of the ceiling of the compartment.

Vents shall have an unrestricted discharge to the outside atmosphere.

Doors or panels providing access to valves shall not require special tools to open.

6.4 Gas equipment

All gas appliances fitted or used externally shall comply with the requirements of SANS 1539. Vapour regulators where installed or fitted shall comply with the requirements of SANS 1237.

6.5 Gas piping systems

6.5.1 General

The requirements of this section shall govern the installation of all fuel gas piping attached to any mobile unit. None of the requirements listed in this section shall apply to the piping supplied as a part of the appliance.

The following requirements shall be applied for the installation of steel piping:

- a) schedule 80 steel pipes may, for sizes up to and including 80 mm, be threaded;
- b) schedule 40 steel pipes may, for sizes up to and including 32 mm, be attached;
- c) fittings, be threaded for vapour application only. For sizes above 32 mm, pipes shall be joined only by welding;
- d) for liquid applications up to and including 25 mm, nominal bore (NB) pipe shall be schedule 80 steel pipe (for manifolds see annex I in SANS 10087-1:2008); and;
- e) when threaded connections are used, only taper threads (male and female) shall be allowed.

6.5.2 System design

Unless determined otherwise by specific installed appliances, systems shall be of the vapour-withdrawal type. Vapour, at a pressure not over 2,8 kPa, shall be delivered from the regulator into the gas appliance supply connection. All systems shall be designed to include the layout of the pipe work to the various appliances to ensure that the required gas demand is achieved.

6.5.3 Gas piping materials

6.5.3.1 General

Materials used for the installation, extension, alteration, of any gas piping system shall be new and free from defects or internal obstructions. Deteriorated or defective materials in gas piping or fittings shall be replaced and shall not be repaired.

Gas piping system shall be permitted to consist of one or more of the following materials where compatible:

- a) solid drawn soft copper tube with copper or copper alloy fittings (At least class I tubing): SANS 460;
- b) corrugated stainless steel piping with associated fittings: BS 7838, EN 15266 or ANSI/CSA LC 1a;
- c) brass fittings that are protected against seasonal cracking: SANS 1067-1.
- d) steel piping to schedule 40 for vapour systems and schedule 80 for liquid withdrawal systems;
- e) compression type jointing (flared type of fitting) is recommended for copper piping. However, brazed joints are satisfactory. Where compression fittings are used, they shall only be used with class II copper pipe;

SANS 10087-2:2011

Edition 3

- f) flexible hose: BS 3212 or SANS 1156-2;
- g) bundy tubing;
- h) rubber hose (braided) type 1: EN 853 (LPG compatible);
- i) jointing materials and compounds: BS 5292; and
- j) polyethylene/aluminium cross linked polyethylene/aluminium macro composite pipe systems for pressure applications: AS 4176 or SANS 17484-1.

6.5.3.2 Design installation and layout of pipework

6.5.3.2.1 Where relevant, the design requirements for the container using pigtails shall comply with SANS 10087-1. Material and testing requirements for this system are given in annex I of SANS 10087-1:2008.

6.5.3.2.2 The low-pressure section of the system shall comply with the following requirements:

- a) Pipework shall not be located where physical damage to the pipe is likely to occur, unless protection is provided.
- b) There shall be no mechanical joints in consumer piping:
 - 1) in locations which are not readily accessible;
 - 2) between the branch point and a joint used for the connection of the appliance; or
 - 3) where the piping passes through a sleeping accommodation area or through an engine compartment.
- c) The use of a hose assembly as consumer piping is restricted as follows:
 - 1) the installation is to have one appliance only;
 - 2) the hose assembly is to be in one continuous length from the outlet of the cylinder regulator to the inlet of the appliance;
 - 3) the hose assembly shall not exceed 2 m; and
 - 4) all hose shall be clamped onto the hose nozzle with a hose clamp.
- d) Pipe and fittings shall be free from defects and shall comply with 6.5.3.1.
- e) Where more than one appliance is to be installed, the main run of the consumer piping system shall be located outside the caravan.
- f) Where more than one appliance is to be installed, the design of the consumer piping system shall be such that:
 - 1) each appliance is connected separately to the main run; and
 - 2) the branch pipe enters the interior of the mobile unit closest to the to each appliance gas inlet.
- g) Where consumer piping penetrates a partition, floor or structural member, the pipe shall be protected against abrasion.

NOTE A rubber grommet, or the like, fitted to the piping, will satisfy this requirement.

SANS 10087-2:2011
Edition 3

- h) To avoid the loosening of any component within a consumer piping system, the system shall be designed with allowances for the following:
- 1) thermal expansion and contraction;
 - 2) movement between sections of the structure; and
 - 3) vibration of the structure.
- i) Piping shall be firmly supported, and particular attention shall be given to the strength and security of hangers and similar supports. The intervals between supports and fixings shall be as given in tables 4 and 5.
- j) A support shall be provided within 150 mm of each pipe fitting. Supports shall be provided adjacent to each bend in a pipe. Heavy components installed in the pipeline (for example, regulators, changeover valves, and manifold valves) shall be supported independently of the pipeline. On single applications where the joint is made between the hose and the pipe, the pipe shall be supported at that joint. Proper saddles (steel or brass) should be used and not PVC saddles as these become brittle due to ultraviolet radiation and break easily.
- k) To allow for the use of tools on a joint without damaging the supporting surface, pipework and supports shall be so arranged that joints stand clear of the surface on which they are supported.

Table 4 — Spacing of pipe supports for copper stainless steel and multi-layer pipes

1	2	3
Nominal size of pipe mm	Maximum interval between pipe supports m	
	Vertical runs	Horizontal runs
8	0,6	0,3
10	0,8	0,5
15	0,9	0,6
20	1,2	0,9

Table 5 — Intervals between pipe supports for steel pipes

1	2	3
Nominal size of pipe mm	Maximum interval between pipe supports m	
	Vertical runs	Horizontal runs
10	1,8	1,2
15	2,4	1,8
20	3,0	2,4
25	3,0	2,4

6.6 Gas pipe sizing

Gas piping systems shall be sized so that the supply of gas to all the burners (when alight) is at a steady input pressure of 2,8 kPa while all the appliances are operating at maximum capacity. For typical pipe sizing see SANS 10087-1.

SANS 10087-2:2011

Edition 3

6.7 Joints and fittings (cocks, valves and unions)

6.5.1 Pipe joints in the piping systems, unless welded, brazed, crimped or soldered shall be screw or flared joints that comply with SANS 1109-1 or SANS 1306-1. Copper joints shall be permitted to be made with a single or double flare of 45 °C as for the requirement given for copper pipe and for fittings in SANS 1067-1 and SANS 1067-2.

Sealants shall not be used on copper tubing joints. Ball sleeve or one-piece internal compression-type tubing fittings shall not be used.

6.7.2 Except for welded, brazed or soldered joints, all joints, cocks, valves and unions, shall be readily accessible for maintenance and repair, and all joints shall be so made as to avoid undue strain in the pipe system. The brazing shall comply with the requirements as recommended by the piping manufacturer. When brazed the joints shall be brazed with a material having a melting point exceeding 538 °C. Brazing alloys shall not contain phosphorus.

6.7.3 Compression-type and capillary-type jointing are recommended for copper piping. Only soft solder that complies with S19 and S20 of SANS 24 shall be used for capillary fittings.

6.7.4 Joints in steel pipes can be made by welding, brazing or screwed connection (see also 6.5.3.1). Only a competent person, shall carry out welding and brazing.

6.7.5 In the case of tapered screwed connections, both male and female threads shall be tapered. Particular care shall be taken to ensure that mating screw threads are of the same type, form and designation. No joint shall be made by over-torque of un-mating threads or by relying on the jointing compound for sealing.

6.7.6 Only approved jointing material shall be used on male threads of screwed components. Hemp shall not be used.

6.8 Routing and protection of piping

6.8.1 General

Piping shall be routed to be protected from physical damage, sharp edges, and moving parts. Cognizance shall be taken for the protection of the piping where it is exposed to the elements e.g. under the vehicle.

Where piping passes through walls, floors, partitions, roofs, or similar elements, such piping shall be protected by the use of weather-resistant grommets that shall fit snugly around both the piping and in the hole through which the grommet fits.

6.8.2 LPG supply hose and pigtails

Hose and pigtails used in LPG systems shall be compliant with the requirements of SANS 1156-2 for hose while the pigtail shall comply with EN 853 (proven compatibility for use with LPG) and the hose connectors shall be compliant with the requirements as given in SANS 1539.

Each connecting hose shall be in one piece and shall supply only one appliance, i.e. there shall be no joints or T-junctions along its length.

Flexible hose shall be checked for signs of rupture, cracking and perishing, and shall be replaced if necessary. Flexible tubing and hose older than five years that has been exposed to UV light, shall be replaced automatically.

6.8.3 LPG connections

A low-pressure LPG connection (as indicated in figure 1) where the regulator is connected directly to the gas container shall be made with a flexible hose connected directly between the outlet of the regulator and inlet of the reticulation system. No flexible hose shall be longer than 2 m.

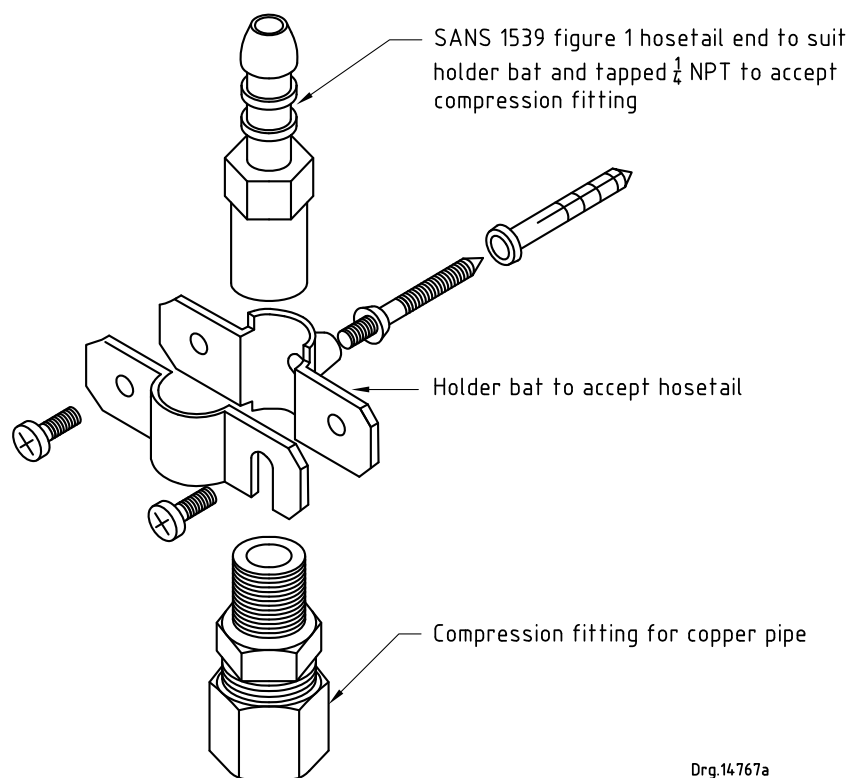

Figure 1 — Typical wall mounted fitting for hose connection

6.8.4 Quick connect couplings

Quick connect couplings used downstream of the low pressure LPG regulator shall be compatible for use with LPG and for the specific environment (indoor or outdoor (or both)) and when uncoupled it shall seal upstream of the fitting.

6.8.5 Shut-off valve

All LPG systems shall include a main shut-off valve the access to which shall be readily accessible.

6.8.6 Prohibiting use of gas piping with electrical supply

Gas piping shall not be laid in the same trunking system as electrical wiring.

7 Inspection, testing, and instructions to users

7.1 Inspection and testing of new installations

On completion, and before commissioning, the installation shall be inspected, tested and approved by the registered installer, and the user shall be issued with a certificate of compliance that indicates that the test has been done and that the installation complies with this part of SANS 10087.

SANS 10087-2:2011

Edition 3

Installations shall be tested in the following sequence:

- a) high-pressure stage;
- b) intermediate pressure stage (when used); and
- c) low-pressure stage.

7.2 High-pressure stage

The valves and high-pressure connections shall be tested for leaks.

NOTE A test method is described in annex A.

7.3 Intermediate pressure stage (when used)

An intermediate pressure stage shall be tested, with inert gas, air or nitrogen, at a pressure of 200 kPa for a minimum period of 10 min. Before this test is carried out, the outlet of the secondary pressure regulator shall be closed.

7.4 Low-pressure stage

The complete low-pressure system shall be tested in accordance with a suitable method (see annex B for one method of testing). When the system is purged of air with the introduction of a flammable gas, precautions shall be taken to avoid a hazardous accumulation of gas escaping from the system.

8 Appliance installation

8.1 Safety and installation requirements

Appliances installed into mobile units shall comply with the safety and installation requirements as given in SANS 1539 and SANS 10087-1.

8.2 Prohibited appliances

The following appliances shall not be installed inside an enclosed mobile unit:

- a) a flueless water heater; and
- b) a space heater, other than a room-sealed type.

8.3 Appliance installed in an enclosure

Where an appliance is to be installed in an enclosure, the following shall apply:

- a) The enclosure is not to be a storage area for flammable materials with a flash point less than 100 °C.
- b) A warning notice, with the wording below is to be fixed in a prominent position, on or adjacent to the appliance.

"THE STORAGE OF FLAMMABLE MATERIALS IN THIS SPACE IS PROHIBITED"

8.4 Restriction for stowed appliances

Appliances installed such that they can be stowed away whilst still connected to the gas supply shall be provided with means to ensure that gas cannot flow when the appliance is in the stowed position.

8.5 Required clearance between appliance and fuel filler cap or vent

Except for mobile units fuelled by diesel, the minimum clearance between a fuel filler cap or fuel tank vent and an appliance flue or combustion air intake shall be 1 m.

8.6 Securing of appliances

An appliance shall be secured to minimize movement or vibration of the appliance and to avoid strain being imparted onto the appliance connection.

8.7 Flueing

An appliance designed to be connected to a flue shall be fitted with a flue which has a minimum clearance of 50 mm between the lowest opening of the flue cowl and the upper surface of the unit in which it is to be installed in a caravan or mobile kitchen.

8.8 Installation of a refrigerator

8.8.1 A refrigerator shall be installed to comply with one of the following:

- a) have the means to exhaust the combustion products to outside atmosphere and terminate at a point not less than 100 mm from an opening into the caravan; and
- b) where a refrigerator is to be installed in a sealed recess, the recess shall have two openings to outside. One opening shall be located at the top of the recess and the other at the bottom. The free ventilation area of each opening shall comply with table 6.

NOTE This requirement provides ventilation to ensure proper operation of the refrigeration unit and includes an allowance for the combustion air requirements of 8.8.2.

Table 6 — Refrigerator storage capacities

1	2
Refrigerator storage capacity L	Minimum free ventilation area cm ²
Not exceeding 100	325
Exceeding 100 but not 200	450
Exceeding 200	650

8.8.2 Air supply to appliances

An area in a caravan where an appliance, other than of a room-sealed type, is installed shall have two openings. The openings shall

- a) provide permanent and unrestricted ventilation;

NOTE In the case of a pop-up type recreation caravan, i.e., one where only the roof extends, the requirement of a) needs to be satisfied whether the top is up or down. However, in the case of a camper-trailer, i.e., one which folds to a trailer profile, the requirement need only be satisfied when the camper-trailer is fully erected.

SANS 10087-2:2011

Edition 3

- b) be located at opposite sides or ends of the area except in the case of pop-up type recreational caravans when the top is down;
- c) subject to (d) comply with table 7; and
- d) each have a minimum free ventilation area calculated using the following formula, but in no case shall the total area of the ventilation openings be less than that given in table 7:

$$A = 3 \times T$$

where

A is the minimum free ventilation area (cm²); and

T is the total gas consumption of all appliances in the area (MJ/h).

Table 7 — Required air supply to appliances installed within the living area

1	2	3	4	5	6
Internal length of caravan m	Minimum free ventilation area cm ²	Minimum openings at each level	Minimum amount of ventilation to be provided at each level	Location of openings	
				Upper level	Lower level
Up to 4	240	1	50 %	To be within 300 mm of the highest part of the ceiling or roof	To be within 150 mm of the floor and unrestricted
Over 4 and up to 5	300				
Over 5 and up to 6	360				
Over 6	420				

9 Instructions to users

9.1 Instruction label

Consumer instructions displayed near an appliance in the form of a printed instruction sheet shall be located in a prominent position near an appliance. The sheet shall be protected from damage and contain the following instructions:

- a) Close appliance valves before opening cylinder valve.
- b) Check connection at the appliances, regulators and cylinders periodically for leaks with soapy water or its equivalent. This should be done at least annually.
- c) Never use a match or flame when checking leaks.
- d) Cylinder valves and appliances are to be closed when not in use.
- e) All appliances shall be turned off and cylinder valve closed when the vehicle is in motion or whilst re-fuelling the motor vehicle is in progress.
- f) In the event of an accidental gas leak, close cylinder valve and ventilate the caravan until air is clear.
- g) Never use cooking appliances for comfort heating.

SANS 10087-2:2011
Edition 3

- h) In the event of fire, immediately close cylinder valve.
- i) All additions or alterations to the LPG system shall be performed by a registered gas installer.
- j) Persons should familiarize themselves with the odour of LPG to assist in the early detection of leaks.
- k) All permanent ventilators, flues and vents should be checked regularly to ensure that they are unobstructed and clear.
- l) When operating appliances, pop-up roofs where fitted shall be elevated.

9.2 Installation documentation

The registered installer or authorized company representative shall supply the user with a printed instruction sheet or booklet describing the correct and safe handling of the LPG systems and appliances, and appropriate general emergency procedures.

In particular, attention shall be drawn to:

- a) the changing of containers and the risks involved,
- b) the action to be taken to disperse accidental accumulation of gas,
- c) the action to be taken in case of fire, and
- d) the fact that the so-called "empty" containers can be dangerous and shall be kept closed at all times.

All the above details shall be discussed with the user to ensure that he fully understands all the details. His attention shall also be drawn to the information and warnings (when relevant) given in the product brochures supplied with the appliance.

9.3 Certificate of compliance

On completion of the installation, the registered installer shall provide a certificate of compliance to the user.

10 Mobile kitchens

10.1 Installation of LPG vapour systems, appliances, cylinders, pipework and fittings (see annex C)

10.1.1 Cylinders on the vehicle or trailer shall be located in a position which minimizes the risk of damage in a road accident. (See also 6.3.2.)

10.1.2 They shall be located in a well ventilated housing mounted on the vehicle within a compartment sealed from the interior of the vehicle, recessed into the body of the vehicle with access to the compartment from the outside of the vehicle. This is only applicable where the operator of the appliance(s) is inside the vehicle. See also 6.3.2.

10.1.3 Compartments including the base, should be constructed of materials which provides a standard minimum of 30 min fire resistance (see SANS 10400) with joints fire stopped to maintain the fire resistance standard. They should be located preferably to the nearside of the vehicle to afford the greatest protection from traffic accident, mechanical damage and for the protection of persons changing cylinders. External housings should be of such construction as to afford protection as far as reasonably practicable in the event of a road traffic accident. (See 6.3.5.)

SANS 10087-2:2011

Edition 3

10.2 Installation of LPG liquid withdrawal systems, and related accessories

10.2.1 Where the operator of the appliance(s) is outside the vehicle the following requirements shall apply:

- a) Installation of LPG appliances, pipework and fittings at vehicle trailer manufacturer's factory premises shall be carried out by qualified and competent staff.
- b) Commissioning of these installations shall be carried out by an authorized person as defined in the relevant national legislation (see foreword).
- c) Subsequent work, inspection, and servicing shall be carried out by an authorized person.

10.2.2 No source of ignition should be within a zone extending 1 m horizontal radius outside the vehicle and from ground level up to 0,3 m above a housing compartment vent. Shielding should be provided if necessary to prevent exhaust pipes becoming an ignition source. It is essential also that acceptable means for securing cylinders in the upright position are provided to prevent movement during transit. See also 6.3.3.

10.2.3 The compartment shall be ventilated with at least two vents having an aggregate free area equal to at least 1 cm² per 500 g of the total LPG fuel capacity of the maximum number of largest container(s) the compartment can hold. (See 6.3.5.)

10.3 Access, doors and panels

10.3.1 Access to cylinder compartments shall be from outside the vehicle and designed to enable easy access for cylinder changing, access to cylinder valves or quick removal of cylinders in an emergency. Unauthorized access shall be prevented when the vehicle is unattended.

10.3.2 The number of cylinders kept on the vehicle should be no more than required to meet the rated requirements of appliances used.

10.3.3 A suitable notice shall be fixed to the exterior of the housing or compartment to warn of the presence of gas. The following pictorial signs PV1, PV2, PV3, PV27, shall conform to the requirements of SANS 1186-1 and shall be fitted in a prominent position. A warning sign with the words "Flammable Gas" shall be affixed to the outside of the gas compartment in a prominent position.

10.3.4 Cylinders may be located outside the vehicle during use when parked, provided they are adjacent to the vehicle on firm and level ground. As far as reasonably practicable locations under openings or close to doors, ventilators or openable windows shall be avoided. Cylinders shall not be located where they would be vulnerable to being struck by passing vehicles nor where operators may be put at risk whilst changing cylinders. For installation safety distances see SANS 10087-1.

10.3.5 Cylinders shall not be left or located outside the vehicle unattended in a place to which the public have access unless they are adequately protected against unauthorized interference. Attention is drawn to the requirements for hoses, regulators, manifolds etc. given in clause 12.

11 Gas installation pipework

11.1 The pipework system design and layout shall comply with the requirements of 6.5. Further advice on LPG pipework is contained in SANS 10087-1.

11.2 Unless the cylinder valve(s) is considered adequate for isolating the system in an emergency, consideration shall be given to providing all emergency shut-off valve(s) adjacent to the vehicle exit. An emergency valve is required where two or more cylinders operate through an automatic changeover device. A label indicating the position of this emergency valve shall be attached to the vehicle.

SANS 10087-2:2011

Edition 3

11.3 The size of pipework shall be calculated to ensure that the flow and pressure at each appliance at the anticipated maximum system load is within the limits specified by the manufacturer.

Unless otherwise permitted by appliance design, pipe sizing practice shall be based on a pressure drop of 25 kPa between the outlet of the pressure regulator and any appliance inlet when the installation is subjected to the anticipated maximum load.

11.4 Copper pipework shall not be placed where temperatures exceed 100 °C. Pipework running beneath the vehicle should be installed where most protection is given against mechanical damage such as impact by stones etc. All pipework shall be secured. The pipework installation shall allow for vibration and flexing of the vehicle structure during transit.

11.5 The number of pipe fittings shall be kept to a minimum and changes of direction avoided as far as possible, allowing for flexing of the pipe work during transit. Jointing compounds where used shall be compatible with LPG. Pipe bends should be used where practicable rather than fittings.

11.6 Final connection between rigid pipework and appliances should be made either directly, or in the case of cookers and ovens, by means of flexible hose. Appliance restraint shall be provided to prevent excessive movement which could cause damage to the flexible connection e.g. a stainless steel chain. Restraints shall not be fixed to gas supply pipes.

11.7 Tubing and hoses shall only be as long as necessary to facilitate connection or disconnection of cylinders, or the temporary movement of appliances for service whilst not putting any part into tension or torsion. Flexible hoses for cookers and ovens shall be as short as practicable but in no case exceed 900 mm in length and either:

- a) flexible hose or tubing complying with the requirements of SANS 1156-2 or BS 3212. Such hose shall be protected by armor or overbraiding. It should not be used where it could be subjected to temperatures above 60 °C; or
- b) strip wound flexible hoses complying with BS 669-1.

Warning — Hoses on push-on connectors without the security of hose clips are dangerous and cannot be relied upon to remain attached.

11.8 High pressure stage pipework should be outside of the vehicle or within the compartment referred to in 6.3.5. Flexible hoses should be in accordance with EN 853 with end connections attached by factory assembled swaging or crimping. The high pressure supply from multiple cylinders may be fed to a suitable wall block or manifold.

11.9 Flexible connectors between a regulator and rigid pipework should be in accordance with EN 853 and should be attached to connectors with purpose made hose clips or factory fitted connections.

12 Pressure regulators, automatic changeover devices and pigtails

12.1 Pressure regulators and automatic changeover devices

12.1.1 Cylinder gas pressure should be reduced to appliance pressure by a suitable single or two stage regulator system. Pressure regulators shall comply with the applicable parts of SANS 1237 and have an output gas rate and pressure to suit the appliances installed when running simultaneously. Appliance pressure is usually 2,8 kPa. If an appliance requires a different pressure rating, a separate pipe should be run to that appliance from an additional regulator. The regulator pressure drop at maximum off-take together with the pipework loss shall not exceed that for which the appliances are designed.

SANS 10087-2:2011

Edition 3

12.1.2 Automatic changeover devices should have an indicator to show when the reserve cylinder is in use.

12.1.3 Regulators should be securely fitted in accordance with the manufacturer's instructions.

12.2 Pigtails

12.2.1 Pigtails shall be manufactured from rubber hose reinforced with wire braiding. The hose shall be compliant with EN 853. The end connections of pigtails shall be machine crimped onto the hose or of machine fitted reusable type. Manually fitted clamps are not allowed.

12.2.2 Pigtails shall be supplied with end fittings for direct connection to a cylinder valve, pipework terminal or manifold inlet as required, without the need for intermediary adaptors.

12.2.3 Pigtails shall not exceed 1 m in length.

12.2.4 Pigtails shall be so constructed that their electrical resistance does not exceed 0,75 Ω /m.

12.2.5 Pigtails for liquid withdrawal shall be of internal diameter at least 8 mm in order to ensure cylinder excess flow valve closure.

12.2.6 An indication of the date of manufacture of the pigtail hose shall be evident in a manner to facilitate replacement every five years.

12.2.7 The fitting connecting the cylinder to the manifold shall comply with the valve connection requirements of SANS 199 for liquids or vapour, whichever is applicable.

12.2.8 Pigtail assemblies shall be marked indicating their batch identification which shall be traceable back to a batch certificate of compliance held by the manufacturer. Pigtails for vapour and liquid applications shall withstand a test pressure of 3 000 kPa and manufacturers shall issue the test certificate to this effect on demand.

12.3 Inspection and maintenance (manifolds and pigtails)

12.3.1 The manifold system shall be maintained on a planned inspection basis at intervals not exceeding five years. Flexible pigtails shall be inspected for signs of rupture, cracking, chafing and perishing and shall be replaced if necessary. If flexible pigtails are over five years old, they shall be replaced automatically.

12.3.2 Repair and maintenance shall only be carried out by an authorized person (registered installer) and the faults in the installation shall be rectified in accordance with the requirements of this standard.

12.3.3 The brackets that secure the manifold shall be checked for soundness.

12.3.4 The pipework shall be checked for corrosion and damage.

12.3.5 All valves shall be checked for free and full range of movement, leakage, positive shut off, corrosion and mechanical damage.

12.3.6 The hydrostatic relief valve on liquid manifolds shall be inspected for corrosion and for any ingress of foreign bodies into the operating mechanism. The relief valve shall be replaced if it is more than seven years old.

SANS 10087-2:2011

Edition 3

12.3.7 The regulator shall be checked for corrosion and mechanical damage. Where corrosion or mechanical damage is found the regulator shall be replaced or refurbished.

12.3.8 If fitted, gauges shall be checked for correct operation, and gauge faces shall be cleaned.

12.3.9 The system shall be leak-tested at all joints using a leak detection solution or system. All joints where leaks become evident shall be tightened or remade after the system has been depressurized.

12.3.10 Persons undertaking any routine cylinder changes to a manifold system shall carry out visual inspections of the manifold system. They shall perform a leak check on the cylinder system connections. Any defects found on the manifold system shall be reported to the owner.

12.4 Records

The manifold shall be supplied together with the certificate of manufacture verifying that the design, construction and test procedures comply with all the requirements given in this part of SANS 10087. The serial number, date of manufacture and the manufacturer's name shall appear on the certification issued with the manifold.

13 Appliances (See also SANS 1539)

13.1 General

13.1.1 Appliances shall be compliant with the requirements of SANS 1539 and shall be approved by the manufacturer/supplier for use with LPG. Each appliance shall be issued with a permit by the relevant authority based on a test report issued by an accredited laboratory.

13.1.2 Appliances shall have burners protected by flame supervision devices. Domestic cooker hotplate and grill burners need not be fitted with such devices provided that they are subject to constant supervision and the gas supply to both the burner and the appliance is turned off when they are not in use.

13.1.3 Installation should be to the manufacturer's instructions with guidance from SANS 1539. Appliances should be used and maintained regularly as instructed by the manufacturer.

13.1.4 Appliances should be sited in positions that do not obstruct passageways or exits. They should be firmly fixed to prevent movement while the vehicle is in motion. Appliances shall not be in use while the vehicle is in motion and the gas supply shall be turned off at the cylinders.

13.2 Space heaters

Only fixed heaters should be used. They should preferably be of the room sealed type. Any heater shall be fitted with an atmosphere sensing device which complies with the requirements of SANS 1539.

13.3 Water heaters

Flues shall be provided as recommended in the instructions. Preference shall be given to room sealed appliances. Appliances shall be fitted with flame supervision device to shut off pilot and main gas supply in the event of flame failure. Where an instantaneous sink water heater supplies a shower it shall be flued to outside the vehicle and preferably be room sealed. See SANS 1539.

SANS 10087-2:2011

Edition 3

13.4 Refrigerators

13.4.1 LPG fuelled refrigerators shall be provided with a flue. An additional ventilation area shall be provided in the vehicle floor immediately below the refrigerator to prevent draughts which might extinguish the small burner flame.

13.4.2 Gas fuelled refrigerators shall not be in operation whilst the vehicle is in motion. For continuous operation the refrigerator should be of a type with alternative electrical heating supplied from an on board battery.

13.5 Catering appliances

13.5.1 Boiling rings

Boiling rings shall comply with the requirements of SANS 1539. Flexible hoses should be examined regularly for damage or wear and replaced as necessary.

13.5.2 Fryers and fish and chip ranges

Fryers and fish and chips ranges shall comply with the requirements of SANS 1539. Fryers and fish and chip ranges shall have a canopy or ventilation hood fitted, incorporating a flue to the outside air unless the total fume emissions are such that vehicle trailer ventilation design guarantees adequate removal of excess un-burnt gas to sustain a safe working environment. They shall be designed for easy cleaning and constructed of non-flammable and non-corrodible materials and comply with the requirements of SANS 1850. The canopy shall extend at least 15 cm beyond the cooking area on all sides and have 27 cm² of flue area for every 1 000 cm² of canopy base area.

A non-adjustable overheat thermostat shall be fitted which will shut-off the main burner if the temperature of fat or oil exceeds 230 °C. Manual resetting of the gas supply shall be required and the device shall operate independently of the automatic temperature control gas valve. A control thermostat shall be fitted to prevent the maximum temperature of oil or fat exceeding 205 °C.

14 Ventilation and flues

14.1 All gas burning appliances produce water vapour and carbon dioxide. Concentrations of carbon monoxide can build up if there is depletion of air and combustion products re-circulate back into the burner air or if there is insufficient maintenance resulting in poor combustion. All gas appliances that require flue installation shall comply with BS 5440-1.

It is essential that ventilation is provided in every compartment where an appliance is used. Fixed and non-adjustable ventilation to the outside air is essential at high and low levels in addition to normal adjustable ventilation from windows and doors. Ventilators shall be designed to minimize draughts even in adverse weather conditions. To protect against vermin, screens shall be considered, these shall be accessible for inspection and cleaning and shall be of sufficient gauge to minimize 'lifting' due to accumulation of dust etc.

14.2 Free ventilation shall be provided at a rate of at least 25 cm² for each 3,6 MJ input rating of all appliances or 100 cm² whichever is the greatest. This shall be divided equally between ventilation openings at high level and low level. See also SANS 1539.

14.3 Where required a gas appliance shall be provided with an adequate flue to the manufacturer's instructions. The flue shall be constructed from non-combustible materials and be separated from combustible materials by at least 25 mm. The flue shall be firmly fixed to the vehicle and capable of withstanding vibration during movement of the vehicle. It shall be capable of venting fumes away at high level and away from any openings in the vehicle.

14.4 Details of requirements for flues are contained in SANS 10087-1.

15 Electric generators fuelled by LPG

15.1 Any generator which is to be fuelled by LPG shall be purpose built or be fitted with proper conversion unit. (See SANS 10087-6).

15.2 Housings built onto or into the mobile catering unit for the purpose containing a generator which is intended to operate within the housing shall comply with the following:

- a) access to the housing shall only be from the outside the mobile catering unit;
- b) the housing shall be constructed of materials which provide standard minimum 30 min fire resistance to meet the requirements as given in SANS 10400; and
- c) ventilation at high and low level shall be provided.

15.3 Given the relatively large gas consumption of large generator (2 kW) consideration shall be given to the use of a separate gas supply to ensure the correct operation of all gas appliances in the mobile catering unit.

15.4 Hoses used to connect the generator to the rigid pipework gas supply should not exceed 1,5 m in length. Quick release fittings shall be approved for use with LPG. Hoses shall be factory fitted with appropriate end fittings.

15.5 All electrical connections and installation shall be in accordance with the national legislation (see foreword).

16 Maintenance

16.1 It is essential that frequent checks of the installation are carried out.

16.2 Before daily catering commences, the user shall check the cylinders, pipework and appliances for leakages and defects in the system. Such checks will largely be limited to visual inspections of flexible hoses, joints in pipework, and correct burning and operation of appliances. Any suspected gas leaks can be traced by the use of soapy water solution.

16.3 An annual inspection, test and servicing of the installation shall be undertaken by an authorized person, to ensure gas soundness of pipework and correct operation of appliances, flues and ventilation.

The owner or operator of the mobile unit shall keep a written record of the annual maintenance tests and service work carried out.

17 Training and instruction

Persons responsible for those working in mobile units shall ensure that such personnel have instruction and information on basic LPG characteristics and action to take in an emergency. Instruction shall be given on correct procedures in changing cylinders and correct use of appliances. Written instructions shall be displayed covering at least the advice given in clause 9.

18 Fire precautions

At least two 9 kg dry powder fire extinguishers conforming to SANS 1910 shall be provided and located in a readily accessible position adjacent to an exit. Extinguishers shall be maintained in accordance with SANS 1475-1.

SANS 10087-2:2011

Edition 3

Where frying is carried out, a fire blanket shall be provided.

Where deep fat frying is carried out a 9 L foam extinguisher shall be provided. All additional fire extinguisher suitable for fires associated with the engine shall be provided.

19 Displayed safety instructions

19.1 General

The following instruction shall to be displayed on cylinder compartment door or nearest available location:

- a) LPG cylinders shall always be used and stored in the upright position with valves uppermost.
- b) When the vehicle is not in use, free-standing cylinders shall not be left unattended in any location which is not secure from public access or unauthorized interference. They shall not be kept inside the vehicle.
- c) When the vehicle is in motion the cylinder valves shall be closed and all appliances turned off.

19.2 Changing cylinders

The following procedure is to be displayed on cylinder compartment door or nearest available location:

- a) Extinguish any ignition source.
- b) Where possible change cylinders in the open air.
- c) Ensure that cylinder valves are in the closed position before disconnecting or removing caps or plugs (for single cylinder supplies turn off all appliances).
- d) Make a firm gas connection using the correct spanner or as directed by the cylinder supplier's instructions. Use soapy water or a proprietary leak detection fluid to test the gas tightness. Never use a naked flame.
- e) After reconnecting a single cylinder supply, make sure all appliances are turned off before opening the cylinder valve.

19.3 Action in the event of a gas leak

A gas leak may be detected by smell, or as a result of leak testing; take action, do not ignore it.

19.3.1 If a leak is found or suspected in the pipework, fittings or appliances all persons shall leave the vehicle at once. If it is safe to do so then the following actions may be taken:

- a) Extinguish all naked flames and sources of ignition. Turn off gas supply and the emergency valve.
- b) Shut-off the gas supply at the cylinder(s).
- c) If leak is inside the vehicle open windows or apertures in the vehicle to disperse gas.
- d) Once the vehicle has been evacuated call a competent gas installer to correct the fault.

SANS 10087-2:2011

Edition 3

19.3.2 If a cylinder is found to be leaking the following action shall be taken providing it is safe do so:

- a) Extinguish any nearby sources of ignition.
- b) Stop the leak by closing the cylinder valve or replacing the bung or cap.
- c) If the leak cannot be stopped, the cylinder should be carefully removed to a safe well ventilated area clear of drains, buildings, ignition sources and other cylinders. The cylinder should be suitably marked as faulty and a warning notice prohibiting smoking or other naked lights displayed. On no account should attempts be made to dismantle or replace cylinder valves.
- d) Advise the gas cylinder supplier.

19.4 Action in case of fire

Anyone who discovers a fire in the vehicle or near the vehicle shall:

- a) Raise the alarm.
- b) Call the fire brigade immediately and advise that gas cylinders are present. The fire officer on arrival shall be told what gas cylinders are involved and their location, also any other hazardous materials fuel tanks etc. on the vehicle.
- c) If gas is ignited from a cylinder valve and it is considered safe to do so, either try to turn off the gas or move any nearby cylinders or hazardous materials away.
- d) If in doubt and particularly if there is flame impingement onto a cylinder, evacuate the area immediately and await arrival of the fire brigade.

20 Parking during use

Where parked for use there shall be at least a 1 m distance from any vent or flue terminal of the service vehicle to any other vehicle or structure or external ignition sources. Clear access shall be provided for emergency escape routes or for removal and changing cylinders. Vehicles or units shall not be parked where they would block emergency exits or impede emergency access.

SANS 10087-2:2011
Edition 3

Annex A
(informative)

Testing of the high-pressure stage of an installation

A.1 Testing of the system (see figure A.1)

A.1.1 Close off the low-pressure line.

A.1.2 Break the pigtail joint of container A, and couple a pressure gauge between the pigtail and the valve of the container. (The gauge should have a range of 0 kPa to 600 kPa and a dial of diameter at least 100 mm.)

A.1.3 Close the valve of container B and, by opening the valve of container A, charge the system with gas.

A.1.4 Close the valve of container A and allow the system to stand for 5 min for equalization of temperature.

A.1.5 Note the pressure on the pressure gauge.

A.1.6 Allow the system to stand for a further 10 min. If the gauge pressure does not drop, the installation is sound.

A.1.7 If the pressure drops, test individual joints, using soapy water to detect leaks. For installations that incorporate non-return valves, carry out the test with the gauge attached to each container (in turn).

A.2 Testing of valves

With the pigtails disconnected, test the container valves for leakage, using soapy water.

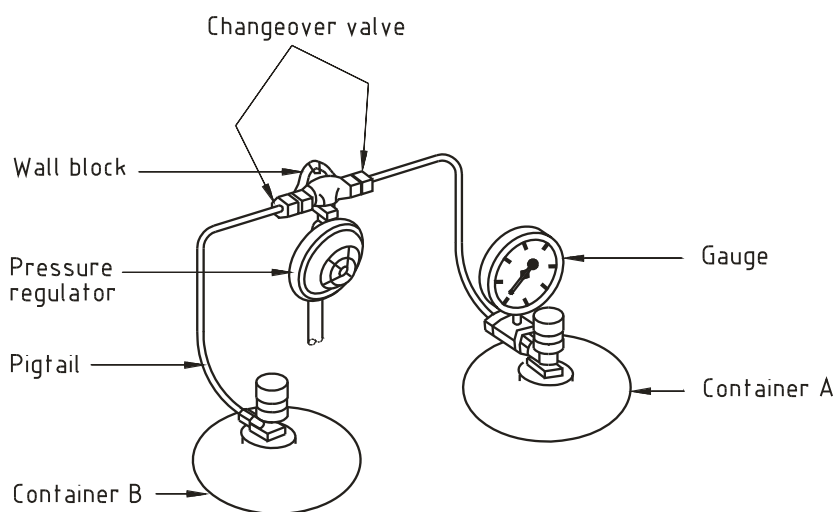

Drg.14.767

NOTE The use of copper pigtails should be discouraged because of work hardening.

Figure A.1 — High-pressure leakage test

Annex B
(informative)

**Testing of the low-pressure stage (as a whole)
of an installation by U-gauge (see figure B.1)**

B.1 The test requires a U-gauge and a fitting, one end of which has a tap and a tube nozzle for connecting the fitting to the U-gauge. The other end of the fitting is for coupling to the supply line under test.

B.2 Make sure that all taps in the gas pipe system (including taps A and B) are closed.

B.3 By opening the container valve, admit gas to the system.

B.4 Open each tap on each appliance (in turn), purge the system of air, taking care to keep a flame near enough to the issuing gas-and-air stream to ignite it when the mixture becomes rich enough, and then close the tap.

B.5 Ensure that the pressure regulator operates at the design pressure of the appliances.

B.6 Open tap A.

B.7 Close the container valve.

B.8 Allow 10 min for temperature stabilization.

B.9 Note the U-gauge reading.

B.10 Close tap A.

B.11 After 10 min, again open tap A, and note the U-gauge reading. Any drop in pressure will indicate that there is a leak.

If this U-gauge reading is lower than that noted in B.9 by more than 25 mm water gauge, there is a leak in the system and the appliance(s), connections, taps, etc., should be carefully examined, and soapy water should be used to detect the leak.

SANS 10087-2:2011
Edition 3

Dimensions in millimetres

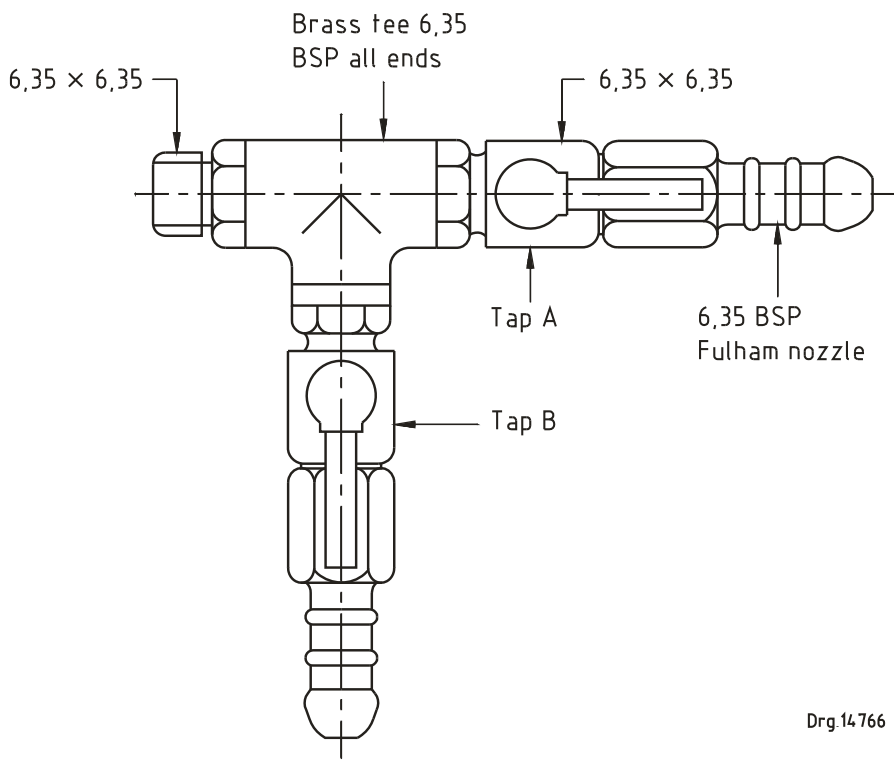

a) Test fitting

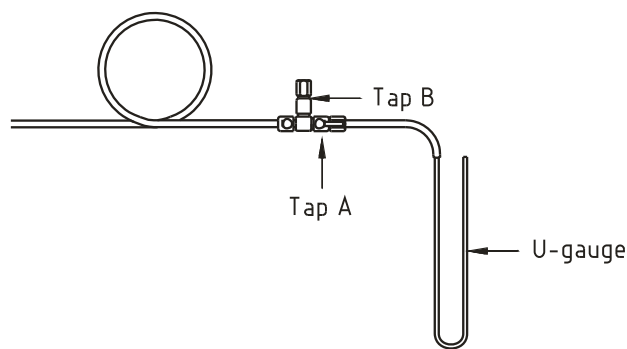

b) Test arrangement

Figure B.1 — U-gauge test

Annex C
(normative)

Installations in mobile units

C.1 Caravans

C.1.1 When cylinders are mounted onto the "A" frame of a mobile unit or forward of the front bulkhead, the cylinder(s) shall be so secured that it cannot be dislodged during transit or while the unit is being towed.

C.1.2 All appliances shall be installed in accordance with the general requirements of this standard and the system shall generally comply to the requirements of SANS 10087-1.

C.2 Mobile homes or park homes

When placed in its temporary or permanent location, mobile homes or park homes, the gas installation shall comply with the requirements as in SANS 10087-1.

C.3 Motor homes

Where LPG containers are mounted into motor home the installer shall ensure that the LPG containers located less than 450 mm from the exhaust system, the transmission, or a heat-producing component of the internal combustion engine shall be shielded by a vehicle frame member or by a non-combustible baffle, with an air space on both sides of the frame member or baffle.

C.4 Trailers or semi-trailers

Containers shall be mounted forward of the front bulkhead below the overhang of a fifth wheel and not lower than the bottom of the trailer frame on trailers or semi-trailers.

SANS 10087-2:2011

Edition 3

Bibliography

BS 669-2, *Flexible hoses, end fittings and sockets for gas burning appliances – Part 2: Specification for corrugated metallic flexible hoses, covers, end fittings and sockets for catering appliances burning 1st, 2nd and 3rd family gases.*

BS 1600, *Specification for dimensions of steel pipe for the petroleum industry.*

EN 549, *Rubber materials for seals and diaphragms for gas appliances and gas equipment.*

EN 1762, *Rubber hoses and hose assemblies for liquefied petroleum gas, LPG (liquid or gaseous phase), and natural gas up to 25 bar (2,5 MPa) – Specification.*

SANS 62-1, *Steel pipes – Part 1: Pipes suitable for threading and of nominal size not exceeding 150 mm.*

SANS 1123, *Pipe flanges.*

SANS 4633/ISO 4633, *Rubber seals – Joint rings for water supply, drainage and sewerage pipelines – Specification for materials.*

SANS 10087-10, *The handling, storage, distribution and maintenance of liquefied petroleum gas in domestic, commercial, and industrial installations – Part 10: Mobile filling stations for refillable liquefied petroleum gas (LPG) containers of capacity not exceeding 9 kg.*

SANS 10108, *The classification of hazardous locations and the selection of apparatus for use in such locations.*

SANS 10140-3, *Identification colour markings – Part 3: Contents of pipelines.*

© SABS

SABS – Standards Division

The objective of the SABS Standards Division is to develop, promote and maintain South African National Standards. This objective is incorporated in the Standards Act, 2008 (Act No. 8 of 2008).

Amendments and Revisions

South African National Standards are updated by amendment or revision. Users of South African National Standards should ensure that they possess the latest amendments or editions.

The SABS continuously strives to improve the quality of its products and services and would therefore be grateful if anyone finding an inaccuracy or ambiguity while using this standard would inform the secretary of the technical committee responsible, the identity of which can be found in the foreword.

Tel: +27 (0) 12 428 6666 Fax: +27 (0) 12 428 6928

The SABS offers an individual notification service, which ensures that subscribers automatically receive notification regarding amendments and revisions to South African National Standards.

Tel: +27 (0) 12 428 6883 Fax: +27 (0) 12 428 6928 E-mail: sales@sabs.co.za

Buying Standards

Contact the Sales Office for South African and international standards, which are available in both electronic and hardcopy format.

Tel: +27 (0) 12 428 6883 Fax: +27 (0) 12 428 6928 E-mail: sales@sabs.co.za

South African National Standards are also available online from the SABS website <http://www.sabs.co.za>

Information on Standards

The Standards Information Centre provides a wide range of standards-related information on both national and international standards, and is the official WTO/TBT enquiry point for South Africa. The Centre also offers an individual updating service called INFOPLUS, which ensures that subscribers automatically receive notification regarding amendments to, and revisions of, international standards.

Tel: +27 (0) 12 428 6666 Fax: +27 (0) 12 428 6928 E-mail: info@sabs.co.za

Copyright

The copyright in a South African National Standard or any other publication published by the SABS Standards Division vests in the SABS. Unless exemption has been granted, no extract may be reproduced, stored in a retrieval system or transmitted in any form or by any means without prior written permission from the SABS Standards Division. This does not preclude the free use, in the course of implementing the standard, of necessary details such as symbols, and size, type or grade designations. If these details are to be used for any purpose other than implementation, prior written permission must be obtained.

Details and advice can be obtained from the Senior Manager.

Tel: +27 (0) 12 428 6666 Fax: +27 (0) 12 428 6928 E-mail: info@sabs.co.za